



**ALLIED MACHINE
& ENGINEERING**

WOHLHAUPTER®

Holemaking Solutions for Today's Manufacturing



Boring



Reaming



Burnishing



Threading



Specials



Structural Steel Solutions

► DRILLING

Replaceable Insert Drills

North America

Allied Machine

120 Deeds Drive
Dover, OH 44622
United States

Allied Machine

485 West 3rd Street
Dover, OH 44622
United States

ThreadMills USA™

4185 Crosstowne Ct #B
Evans, GA 30809
United States

Superion™

1285 S Patton St.
Xenia, OH 45385
United States

Europe

Allied Machine Europe

93 Vantage Point
Pensnett Estate
Kingswinford
West Midlands
DY6 7FR, United Kingdom

Wohlhaupter® GmbH

Maybachstrasse 4
72636 Frickenhausen
Germany

Asia

Wohlhaupter® India

B-23, 2nd Floor
B Block Community Centre
Janakpuri, New Delhi - 110058
India



Allied Machine & Engineering is a worldwide leader in holmaking and finishing solutions. We are committed to providing practical and dependable solutions to our customers through innovative designs and superior customer and technical support.

We continue to expand our product offering in order to provide new and different solutions. With Field Sales Engineers located around the world, we position ourselves to provide technical support on site, right at your spindle.



**ALLIED MACHINE
& ENGINEERING**

WOHLHAUPTER®

Holmaking Solutions for Today's Manufacturing

www.alliedmachine.com

The Foundation

Since 1941, Allied Machine & Engineering has provided dependable and practical holemaking solutions to the world. What was once a small job shop in Ohio is now a worldwide leader in cutting tool technology. With three manufacturing facilities in Ohio, one in Georgia, another in Germany and headquarters in both the United States and Europe, Allied Machine is positioned to bring innovative solutions and technical expertise directly to the customers' hands.



The Beginning

Harold E. Stokey founded Allied Machine & Engineering to aid the war effort, manufacturing taper bearing lock nuts for the production of M1 tanks. Years later, after a sales meeting gone wrong, Stokey possessed a warehouse stocked with spade drill inserts. He set forth into the industry that would become Allied Machine's thriving identity: holemaking.



The T-A®

When Harold's son, William H. Stokey, became the president and CEO, he developed the Throw Away, or T-A®, spade drill insert system. The T-A® revolutionised the holemaking industry, launching Allied Machine ahead of the competition. Since then, numerous innovations and advancements have been created from the T-A®'s inspiration.



The Innovation

Since the development of the T-A®, Allied Machine has expanded its product offering to support a vast range of customer applications, including large diameter and deep hole drilling, boring, reaming, burnishing, porting and threading.

The People

Allied Machine understands that high quality products are only one facet of success. Our customer support is crucial to what we do and that's why we make sure the best engineers and customer service associates are in place to assist our customers around the world.

The Future

With over 75 years of experience, Allied Machine has encountered the challenges of growth and success. By investing in cutting edge technology and the brightest and sharpest minds, our knowledge and capabilities continue to expand and grow every day.



Steve Stokey
Executive Vice President
Allied Machine & Engineering Corp.

Frank-M. Wohlhaupter
Managing Director
Wohlhaupter GmbH

Paul Crawford
Managing Director
AMEC Europe

Mike Stokey
Executive Vice President
Allied Machine & Engineering Corp.

Allied Machine Dover, OH, USA

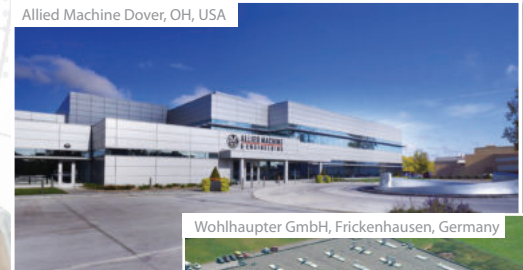

Wohlhaupter GmbH, Frickenhausen, Germany



Allied Machine Europe, Kingswinford, UK



**ALLIED MACHINE
& ENGINEERING**

Holemaking Solutions for Today's Manufacturing

WOHLHAUPTER®



SUPERION™

CRITERION™

Structural Steel Drilling Solutions

Replaceable Insert Drilling System | GEN3SYS® XT Structural Steel | T-A® Original and GEN2 T-A® Structural Steel

- ▶ GEN3SYS®XT Pro ST and XT ST Diameter Range: 12.00mm - 35.00mm (0.4331" - 1.3780")
- ▶ T-A® Structural Steel Diameter Range: 12.98mm - 47.80mm (0.511" - 1.882")



Take on Tough Drilling

Allied Machine's Structural Steel Drilling System is designed for maximum performance in structural steel materials and applications. These solutions utilise the GEN3SYS XT Pro, XT ST, T-A Original, and GEN2 T-A Structural Steel designs and capabilities.

With multiple geometries and coatings, you're sure to find the solution that is right for you. Tough drilling is tough no more.

Excellent chip control	Improves hole quality and surface finish	Provides maximum durability and stability
------------------------	--	---

Applicable Industries



Structural Steel

Your safety and the safety of others is very important. This catalog contains important safety messages. Always read and follow all safety precautions.



This triangle is a safety hazard symbol. It alerts you to potential safety hazards that can cause tool failure and serious injury.

When you see this symbol in the catalog, look for a related safety message that may be near this triangle or referred to in the nearby text.

There are safety signal words also used in the catalog. Safety messages follow these words.

⚠ WARNING

WARNING (shown above) means that failure to follow the precautions in this message could result in tool failure and serious injury.

NOTICE means that failure to follow the precautions in this message could result in damage to the tool or machine but not result in personal injury.

NOTE and **IMPORTANT** are also used. These are important that you read and follow but are not safety-related.

Visit www.alliedmachine.com for the most up-to-date information and procedures.

Reference Icons

The following icons will appear throughout the catalog to help you navigate between products.

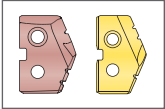

Corresponding T-A Inserts

Refers to the corresponding T-A insert items that connect with each specific holder series

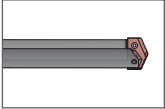

Corresponding T-A Holders

Refers to the corresponding T-A holder items that connect with each specific insert series



Setup / Assembly Information

Detailed instructions and information regarding the corresponding part(s)

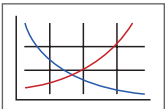

Recommended Cutting Data

Speed and feed recommendations for optimum and safe drilling

Series	GEN3SYS XT Pro ST Diameter Range	
	Metric (mm)	Imperial (inch)
12	12.00 - 12.99	0.4724 - 0.5117
13	13.00 - 13.99	0.5118 - 0.5511
14	14.00 - 14.99	0.5512 - 0.5905
15	15.00 - 15.99	0.5906 - 0.6298
16	16.00 - 16.99	0.6299 - 0.6692
17	17.00 - 17.99	0.6693 - 0.7086
18	18.00 - 19.99	0.7087 - 0.7873
20	20.00 - 21.99	0.7874 - 0.8660
22	22.00 - 23.99	0.8661 - 0.9448
24	24.00 - 25.99	0.9449 - 1.0235
26	26.00 - 28.99	1.0236 - 1.1416
29	29.00 - 31.99	1.1417 - 1.2597
32	32.00 - 35.00	1.2598 - 1.3780

Series	T-A Structural Steel Diameter Range	
	Metric (mm)	Imperial (inch)
0	12.98 - 17.65	0.511 - 0.695
1	17.53 - 24.38	0.690 - 0.960
2	24.41 - 35.05	0.961 - 1.380
3	34.36 - 47.80	1.353 - 1.882

Structural Steel Drilling Solutions Contents

GEN3SYS® XT Pro and XT Structural Steel

GEN3SYS XT Pro ST System Overview 2 - 3

GEN3SYS XT ST System Overview 4

Structural Steel Drilling Overview 5

Product Nomenclature 6 - 7

 12 - 13 Series 8 - 9

 14 - 15 Series 10 - 11

 16 - 17 Series 12 - 13

 18 - 20 Series 14 - 15

 22 - 24 Series 16 - 17

 26 - 29 Series 18 - 19

 32 Series 20

Structural Steel Adaptors DV45 & DV50 21

T-A® Drilling System

T-A System Overview 22

Product Nomenclature 23

 0 Series 24 - 27

 1 Series 28 - 31

 2 Series 32 - 35

 3 Series 36 - 38

Deep Hole Drilling Guidelines 39

Recommended Cutting Data

GEN3SYS XT Pro System 40 - 41

T-A System 42 - 43

Guaranteed Application Form 44 - 45



GEN3SYS® XT Pro ST Structural Steel Drilling System

GEN3SYS® XT PRO *ST*

REPLACEABLE TIP HIGH PENETRATION STRUCTURAL STEEL *SOLUTION*

The challenge of drilling structural steel materials is about to get a whole lot easier. Developed through a rigorous and thorough testing process, the modified and improved XT Pro ST is a product of innovation.

Achieve the **consistent performance** you need and exceed your current parameters.



View the **NEW** Video at
www.alliedmachine.com

GEN3SYS® XT ST and Pro ST

T-A® Structural Steel

Cutting Data & Guaranteed Application Forms

GEN3SYS® XT Pro ST Structural Steel Drilling System

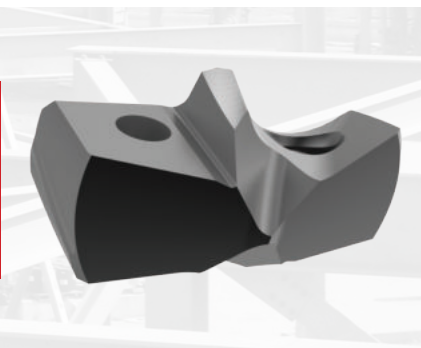

GEN3SYS® XT ST and Pro ST

T-A® Structural Steel

Cutting Data & Guaranteed Application Forms

GEN3SYS® XT Pro **ST**
STRUCTURAL STEEL ENHANCEMENTS

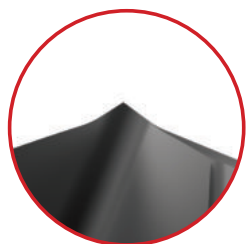

New Point Design
Increases stability without hindering penetration

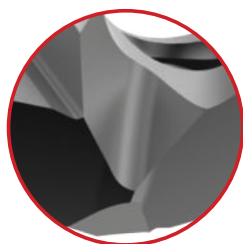

Redesigned Insert
Provides consistent performance and adds durability

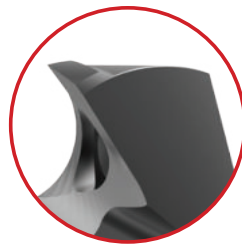

Improved Geometry
Extends tool life and increases insert strength without increasing horsepower consumption



AM420 Coating
Increases heat threshold and extends tool life



3xD

5xD

7xD

Get the Consistency You Need

The challenge of drilling structural steel materials is about to get a whole lot easier. Developed through a rigorous and thorough testing process, the modified and improved XT ST insert is a product of innovation.

Achieve the **consistent performance** you need while matching or even exceeding your current parameters.

Tough Drilling is Tough No More

Structural steel applications can prove to be difficult to machine, so you need a drill that's been put through the fire to ensure it can conquer those challenging applications.

Rigorous testing and countless hours of design and programming make the XT Pro ST the optimal drill for structural steel applications.

- Diameter range: 12mm - 35mm
- Holders available in 3xD, 5xD, and 7xD lengths
- Flanged shank with flat
- Through Tool Coolant
- Fits on to existing GEN3SYS® XT ST holders



NOTICE: GEN3SYS XT Structural Steel holders are specifically designed to be used only with XT Pro ST or XT ST geometry inserts. Using other GEN3SYS XT Pro or XT insert geometries in these holders could lead to chip packing and tool failure. Contact Application Engineering for questions regarding proper use of tools.

GEN3SYS® XT Structural Steel Drilling System

STRUCTURAL STEEL | GEN3SYS® XT ST

GEN3SYS® XT ST and Pro ST

T-A® Structural Steel

Cutting Data & Guaranteed Application Forms

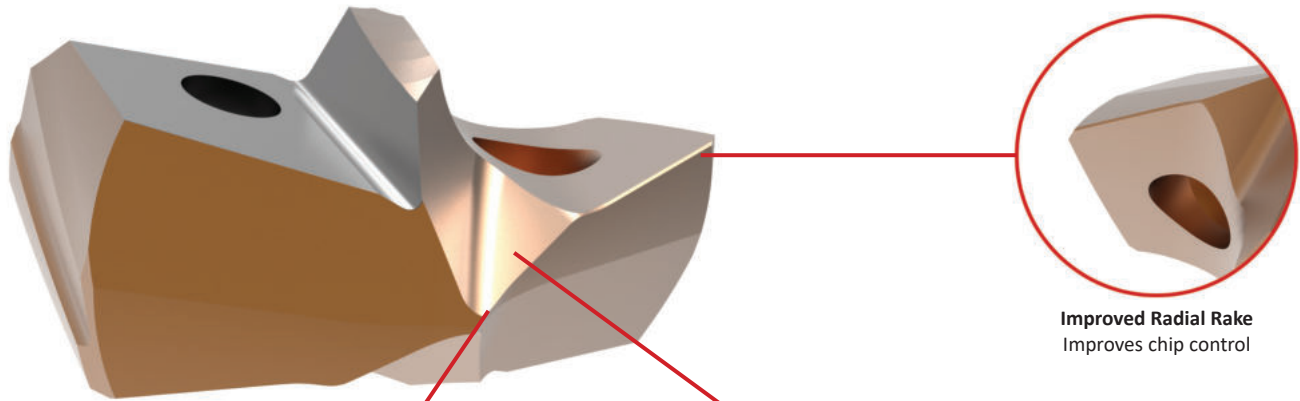

Available in AM300® Coating

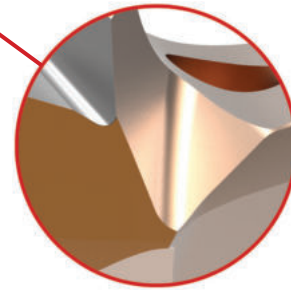
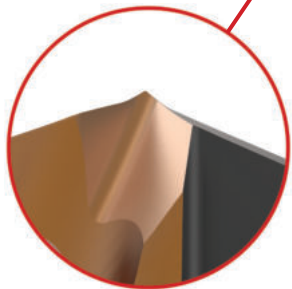

Holder Anatomy

1. Flanged Shank with Flat
2. Coolant Inlet
3. Flute (straight only)
4. Coolant Outlets



Straight Flute

NOTICE: GEN3SYS XT Structural Steel holders are specifically designed to be used only with XT Pro ST or XT ST geometry inserts. Using other GEN3SYS XT Pro or XT insert geometries in these holders could lead to chip packing and tool failure. Contact Application Engineering for questions regarding proper use of tools.

Structural Steel Drilling

Achieving Optimal Results in Structural Steel

Drilling in structural steel materials can be a difficult process, and achieving optimal results becomes a major issue. Allied Machine's structural steel drilling solutions have been specifically designed to produce the best results in the toughest materials. With solutions in both the T-A® and GEN3SYS® XT Pro product lines, you have multiple options to solve your application problems.

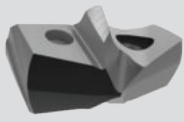
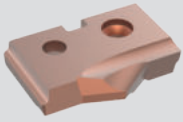
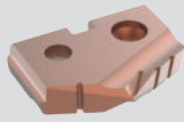
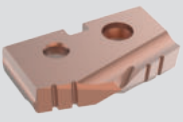
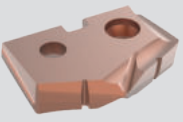

Insert Style Comparison

	 GEN3SYS® XT Pro ST GEN3SYS®XT ST	 Original T-A® Thin Wall	 Original T-A® Notch Point®	 Original T-A® 150° Structural Steel	 GEN2 T-A® High Efficiency
High penetration	<input checked="" type="checkbox"/>				
Material less than 6mm thick		<input checked="" type="checkbox"/>			
Material over 6mm thick	<input checked="" type="checkbox"/>		<input checked="" type="checkbox"/>	<input checked="" type="checkbox"/>	<input checked="" type="checkbox"/>
Reduced exit burr			<input checked="" type="checkbox"/>	<input checked="" type="checkbox"/>	
Includes Notch Point® geometry			<input checked="" type="checkbox"/>	<input checked="" type="checkbox"/>	<input checked="" type="checkbox"/>
Available from carbide	<input checked="" type="checkbox"/>				<input checked="" type="checkbox"/>
Stocked in common sizes for the Structural Steel industry	<input checked="" type="checkbox"/>	<input checked="" type="checkbox"/>	<input checked="" type="checkbox"/>	<input checked="" type="checkbox"/>	<input checked="" type="checkbox"/>

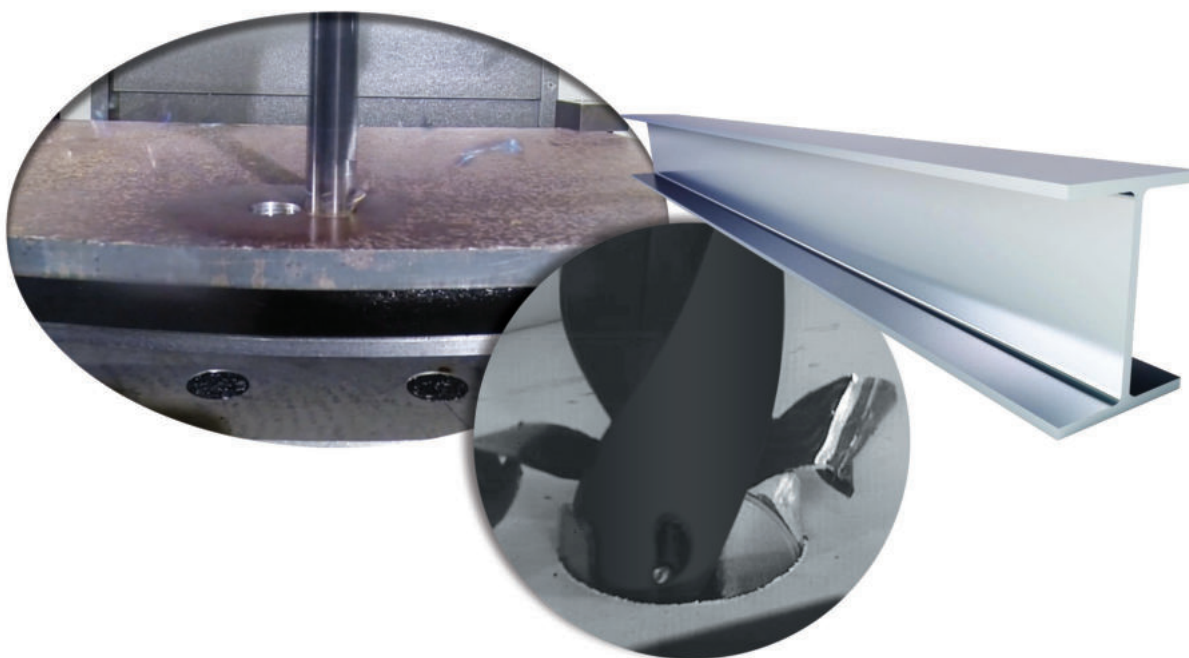

GEN3SYS®XT ST and Pro ST

T-A® Structural Steel

Cutting Data & Guaranteed Application Forms

GEN3SYS® XT Pro ST / GEN3SYS® XT ST Drill Insert Nomenclature

GEN3SYS®XT Pro Drill Inserts

XT	ST	20	-	20.00
1	2	3		4

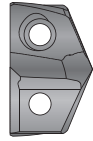

1. XT Pro ST Drill Insert XT = XT Pro insert	2. Geometry ST = Structural Steel	3. Series <table border="0"> <tr> <td>12 = 12 series</td> <td>17 = 17 series</td> <td>26 = 26 series</td> </tr> <tr> <td>13 = 13 series</td> <td>18 = 18 series</td> <td>29 = 29 series</td> </tr> <tr> <td>14 = 14 series</td> <td>20 = 20 series</td> <td>32 = 32 series</td> </tr> <tr> <td>15 = 15 series</td> <td>22 = 22 series</td> <td></td> </tr> <tr> <td>16 = 16 series</td> <td>24 = 24 series</td> <td></td> </tr> </table>	12 = 12 series	17 = 17 series	26 = 26 series	13 = 13 series	18 = 18 series	29 = 29 series	14 = 14 series	20 = 20 series	32 = 32 series	15 = 15 series	22 = 22 series		16 = 16 series	24 = 24 series		4. Diameter (mm) For complete list of diameter ranges by series, see contents page.
12 = 12 series	17 = 17 series	26 = 26 series																
13 = 13 series	18 = 18 series	29 = 29 series																
14 = 14 series	20 = 20 series	32 = 32 series																
15 = 15 series	22 = 22 series																	
16 = 16 series	24 = 24 series																	

Reference Key

Symbol	Attribute
D_1	Insert diameter

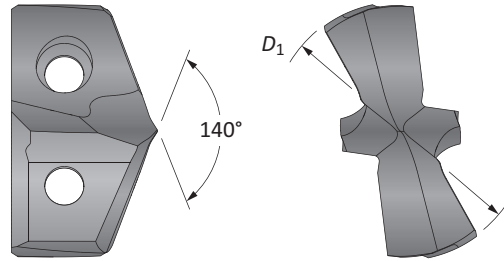

Sizes not shown are available upon request.
When ordering, please follow the example below:

Metric:	20.10mm, 20 series = use Part No. XTST20-20.10
Imperial:	0.7913", 20 series = use Part No. XTST20-20.10

GEN3SYS®XT ST Drill Inserts

7	C2	14	P	-	0018	ST
1	2	3	4		5	6

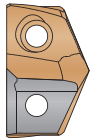

1. XT Drill Insert 7 = XT insert	2. Insert Material C2 = K20 (C2) carbide	3. Series <table border="0"> <tr> <td>12 = 12 series</td> <td>17 = 17 series</td> <td>24 = 24 series</td> </tr> <tr> <td>14 = 14 series</td> <td>18 = 18 series</td> <td>26 = 26 series</td> </tr> <tr> <td>15 = 15 series</td> <td>20 = 20 series</td> <td>29 = 29 series</td> </tr> <tr> <td>16 = 16 series</td> <td>22 = 22 series</td> <td>32 = 32 series</td> </tr> </table>	12 = 12 series	17 = 17 series	24 = 24 series	14 = 14 series	18 = 18 series	26 = 26 series	15 = 15 series	20 = 20 series	29 = 29 series	16 = 16 series	22 = 22 series	32 = 32 series	4. Coating P = AM300®
12 = 12 series	17 = 17 series	24 = 24 series													
14 = 14 series	18 = 18 series	26 = 26 series													
15 = 15 series	20 = 20 series	29 = 29 series													
16 = 16 series	22 = 22 series	32 = 32 series													

5. Diameter 18 = Metric 0102 = Inch	6. Geometry ST = Structural steel
--	---

Reference Key

Symbol	Attribute
D_1	Insert diameter

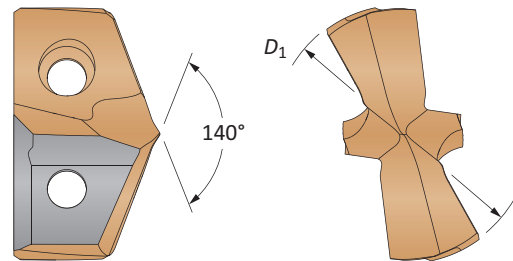

GEN3SYS® XT Structural Steel Drill Holder Nomenclature

GEN3SYS®XT Structural Steel Drill Holders

ST	03	12	0	-	20	FM
1	2	3	4		5	6

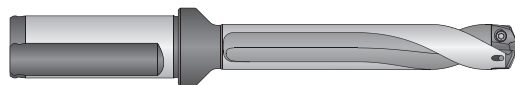

1. Holder ST = Structural steel holder	2. Length 03 = 3x Diameter 05 = 5x Diameter 07 = 7x Diameter	3. Series 12 = 12 series 17 = 17 series 26 = 26 series 13 = 13 series 18 = 18 series 29 = 29 series 14 = 14 series 20 = 20 series 32 = 32 series 15 = 15 series 22 = 22 series 16 = 16 series 24 = 24 series	4. Body Diameter 0 = Standard 5 = Oversized								
5. Shank Diameter <table border="1"> <thead> <tr> <th>Metric (mm)</th> <th>Imperial (in)</th> </tr> </thead> <tbody> <tr> <td>16 = 16mm 32 = 32mm</td> <td>063 = 5/8" 125 = 1-1/4"</td> </tr> <tr> <td>20 = 20mm 40 = 40mm</td> <td>075 = 3/4" 150 = 1-1/2"</td> </tr> <tr> <td>25 = 25mm</td> <td>100 = 1"</td> </tr> </tbody> </table>		Metric (mm)	Imperial (in)	16 = 16mm 32 = 32mm	063 = 5/8" 125 = 1-1/4"	20 = 20mm 40 = 40mm	075 = 3/4" 150 = 1-1/2"	25 = 25mm	100 = 1"	6. Shank Style F = Flanged with flat FM = Flanged metric with flat C = Cylindrical (no flat) CM = Cylindrical metric (no flat)	
Metric (mm)	Imperial (in)										
16 = 16mm 32 = 32mm	063 = 5/8" 125 = 1-1/4"										
20 = 20mm 40 = 40mm	075 = 3/4" 150 = 1-1/2"										
25 = 25mm	100 = 1"										

Reference Key

Symbol	Attribute
D_2	Shank diameter
L_1	Overall length
L_2	Drill depth
L_3	Holder reference length
L_4	Holder body length
L_7	Shank length
P_1	Rear pipe tap

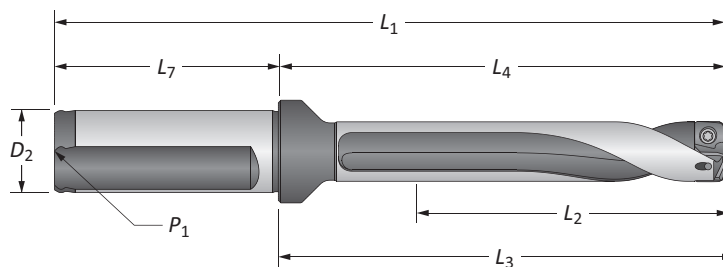



NOTICE: GEN3SYS®XT Structural Steel Holders are suitable for both GEN3SYS®XT Pro ST and GEN3SYS®XT ST Inserts ONLY.

GEN3SYS® XT Pro ST / GEN3SYS® XT ST Structural Steel Drilling System

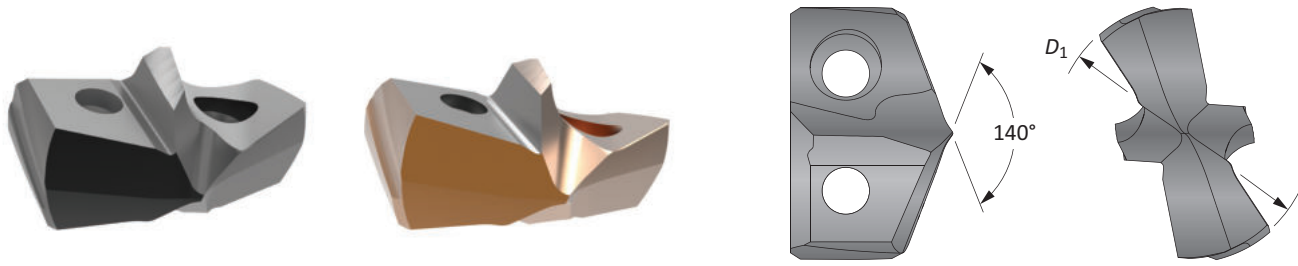
12 Series | Diameter Range: 12.00mm - 12.99mm (0.4724" - 0.5117")



Inserts

Insert				
D ₁ mm	D ₁ inch	Fractional Equivalent	XT Pro ST Part No.	XT ST Part No.
12.00	0.4724	-	XTST12-12.00	7C212P-12ST
13.00	0.5118	-	-	7C212P-13ST

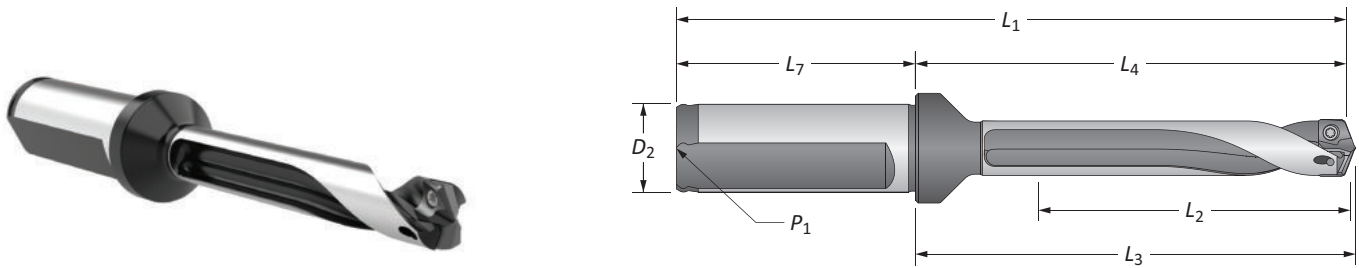





Holders

Length	Body				Shank				Part No.
	L ₂	L ₄	L ₃	L ₁	L ₇	D ₂	P ₁	Flat	
m 3xD	39.0	66.6	68.6	116.6	50	20	3.18*	YES	ST03120-20FM
m 5xD	65.0	92.6	94.8	142.6	50	20	3.18*	YES	ST05120-20FM
m 7xD	91.0	118.5	120.8	168.5	50	20	3.18*	YES	ST07120-20FM
i 3xD	1-17/32	2-5/8	2-45/64	4-21/32	2-1/32	3/4	1/8	YES	ST03120-075F
i 5xD	2-9/16	3-41/64	3-47/64	5-43/64	2-1/32	3/4	1/8	YES	ST05120-075F
i 7xD	3-37/64	4-43/64	4-3/4	6-45/64	2-1/32	3/4	1/8	YES	ST07120-075F

*Thread to BSP and ISO 7-1

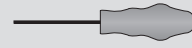
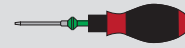
Connection Accessories

					Admissible Tightening Torque*
7247-IP7-1	7247N-IP7-1	8IP-7	8IP-7TL	8IP-7B	84 N-cm (7.4 in-lbs)

*Tightening torques are calculated with a friction coefficient of $\mu = 0.14$ and develop 90% of ultimate yield strength

40-41

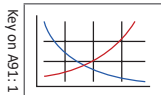

m = Metric (mm)
i = Imperial (in)

Inserts sold in multiples of 1 | Screws sold in multiples of 10

NOTICE: GEN3SYS XT Structural Steel holders are specifically designed to be used only with XT Pro ST or XT ST geometry inserts. Using other GEN3SYS XT Pro or XT insert geometries in these holders could lead to chip packing and tool failure. Contact Application Engineering for questions regarding proper use of tools.

GEN3SYS® XT Pro ST / GEN3SYS® XT ST Structural Steel Drilling System

13 Series | Diameter Range: 13.00mm - 13.99mm (0.5118" - 0.5111")

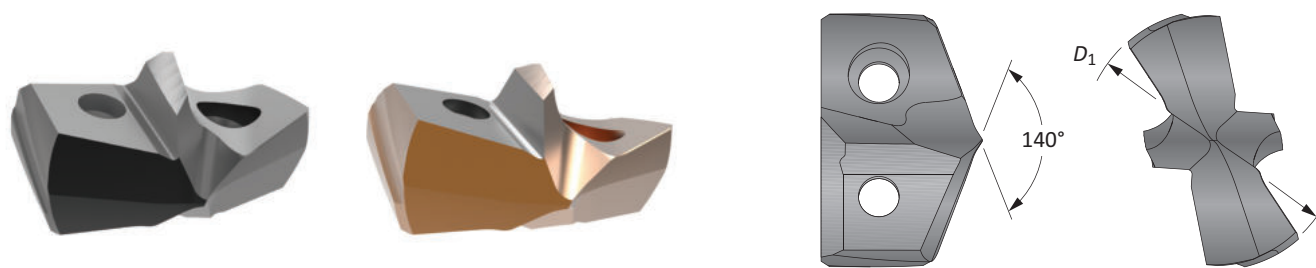

Inserts

Insert				
D ₁ mm	D ₁ inch	Fractional Equivalent	XT Pro ST Part No.	XT ST Part No.
13.00	0.5118	-	XTST13-13.00	-

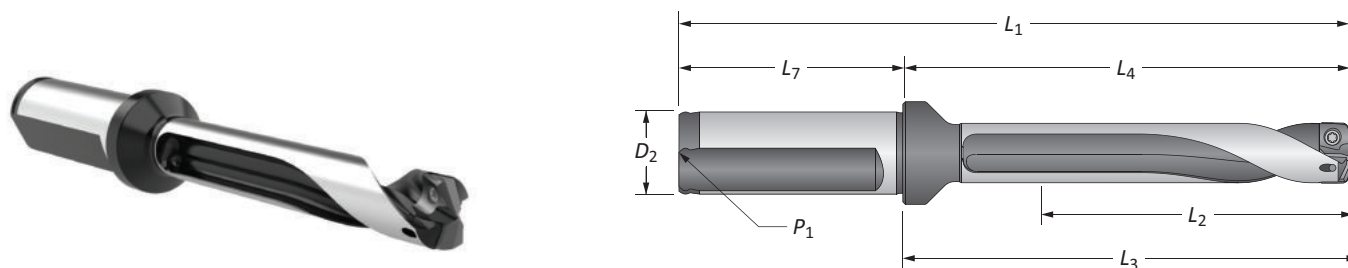

Holders

Length	Body				Shank					Part No.
	L ₂	L ₄	L ₃	L ₁	L ₇	D ₂	P ₁	Flat		
m 3xD	39.0	66.6	68.6	116.6	50	20	3.18*	YES	ST03130-20FM	
5xD	65.0	92.6	94.8	142.6	50	20	3.18*	YES	ST05130-20FM	
7xD	91.0	118.5	120.8	168.5	50	20	3.18*	YES	ST07130-20FM	
i 3xD	1-17/32	2-5/8	2-45/64	4-21/32	2-1/32	3/4	1/8	YES	ST03130-075F	
5xD	2-9/16	3-41/64	3-47/64	5-43/64	2-1/32	3/4	1/8	YES	ST05130-075F	
7xD	3-37/64	4-43/64	4-3/4	6-45/64	2-1/32	3/4	1/8	YES	ST07130-075F	

*Thread to BSP and ISO 7-1

Connection Accessories

					Admissible Tightening Torque*
7247-IP7-1	7247N-IP7-1	8IP-7	8IP-7TL	8IP-7B	84 N-cm (7.4 in-lbs)

*Tightening torques are calculated with a friction coefficient of $\mu = 0.14$ and develop 90% of ultimate yield strength

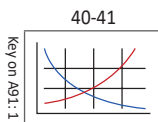

m = Metric (mm)
i = Imperial (in)

Inserts sold in multiples of 1 | Screws sold in multiples of 10



NOTICE: GEN3SYS XT Structural Steel holders are specifically designed to be used only with XT Pro ST or XT ST geometry inserts. Using other GEN3SYS XT Pro or XT insert geometries in these holders could lead to chip packing and tool failure. Contact Application Engineering for questions regarding proper use of tools.

GEN3SYS® XT Pro ST / GEN3SYS® XT ST Structural Steel Drilling System

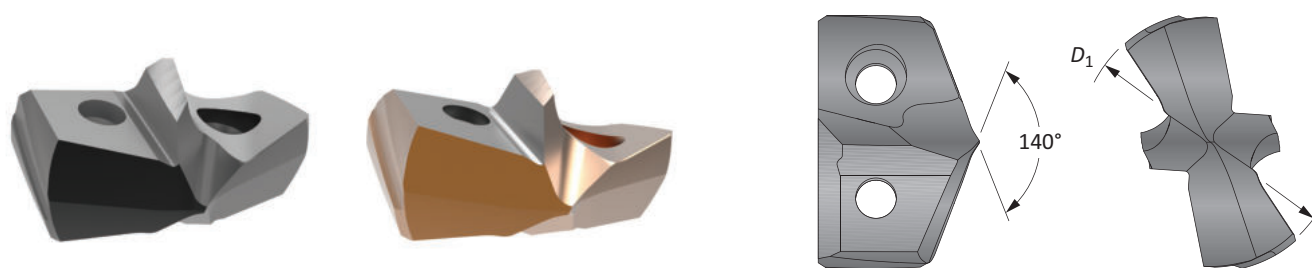
14 Series | Diameter Range: 14.00mm - 14.99mm (0.5512" - 0.5905")



Inserts

Insert				
D_1 mm	D_1 inch	Fractional Equivalent	XT Pro ST Part No.	XT ST Part No.
14.00	0.5512	-	XTST14-14.00	7C214P-14ST
14.29	0.5625	9/16	XTST14-14.29	7C214P-0018ST

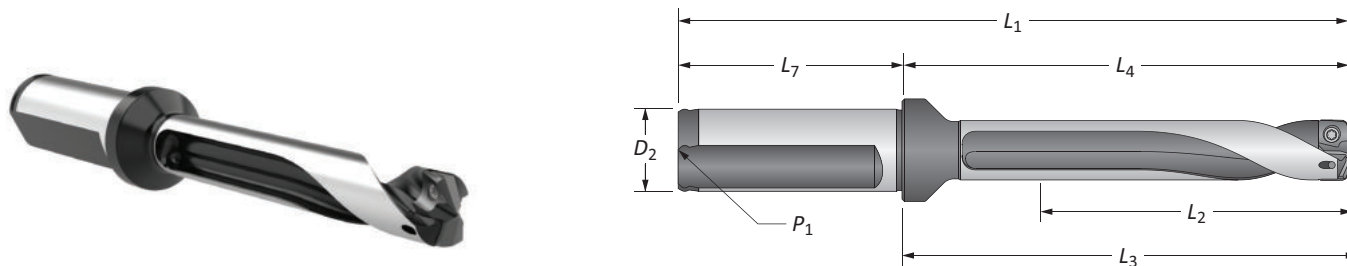





Holders

Length	Body				Shank				Flat	Part No.
	L_2	L_4	L_3	L_1	L_7	D_2	P_1			
3xD	45.0	72.4	75.0	122.4	50	20	3.18*	YES	ST03140-20FM	
5xD	75.0	102.4	104.9	152.4	50	20	3.18*	YES	ST05140-20FM	
7xD	104.9	132.3	134.9	182.3	50	20	3.18*	YES	ST07140-20FM	
3xD	1-25/32	2-27/32	2-61/64	4-7/8	2-1/32	3/4	1/8	YES	ST03140-075F	
5xD	2-61/64	4-1/32	4-1/8	6-1/16	2-1/32	3/4	1/8	YES	ST05140-075F	
7xD	4-9/64	5-13/64	5-5/16	7-15/64	2-1/32	3/4	1/8	YES	ST07140-075F	

*Thread to BSP and ISO 7-1

Connection Accessories

					Admissible Tightening Torque*
7247-IP7-1	7247N-IP7-1	8IP-7	8IP-7TL	8IP-7B	84 N-cm (7.4 in-lbs)

*Tightening torques are calculated with a friction coefficient of $\mu = 0.14$ and develop 90% of ultimate yield strength

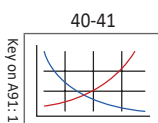

M = Metric (mm)
I = Imperial (in)

Inserts sold in multiples of 1 | Screws sold in multiples of 10

NOTICE: GEN3SYS XT Structural Steel holders are specifically designed to be used only with XT Pro ST or XT ST geometry inserts. Using other GEN3SYS XT Pro or XT insert geometries in these holders could lead to chip packing and tool failure. Contact Application Engineering for questions regarding proper use of tools.

GEN3SYS® XT Pro ST / GEN3SYS® XT ST Structural Steel Drilling System

15 Series | Diameter Range: 15.00mm - 15.99mm (0.5906" - 0.6298")

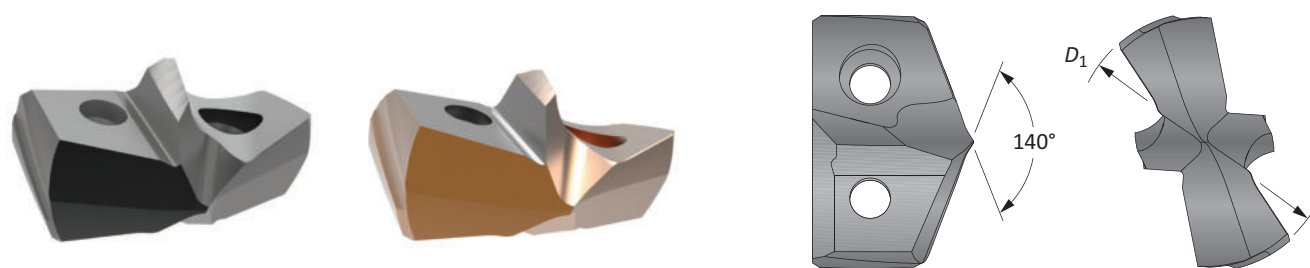

Inserts

D ₁ mm	Insert		XT Pro ST Part No.	XT ST Part No.
	D ₁ inch	Fractional Equivalent		
15.00	0.5906	–	XTST15-15.00	7C215P-15ST
15.88	0.6250	5/8	XTST15-15.88	7C215P-0020ST

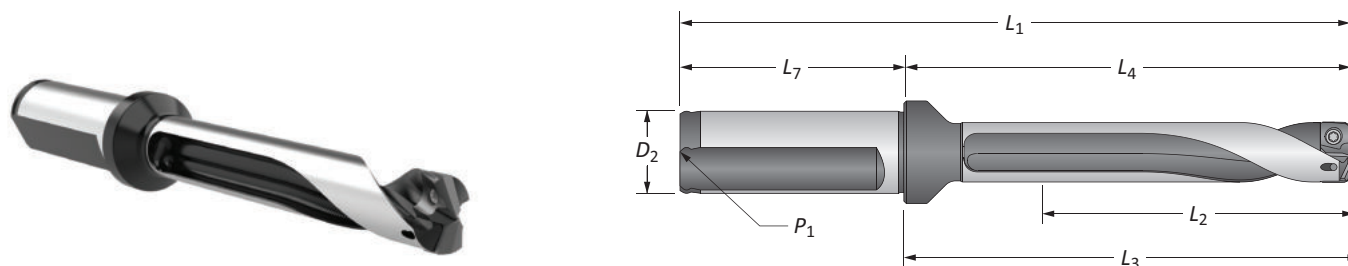

Holders

Length	Body				Shank					Part No.
	L ₂	L ₄	L ₃	L ₁	L ₇	D ₂	P ₁	Flat		
m	3xD	48.0	75.1	77.6	125.1	50	20	3.18*	YES	ST03150-20FM
	5xD	80.0	107.0	109.6	157.0	50	20	3.18*	YES	ST05150-20FM
	7xD	111.9	139.0	141.6	189.0	50	20	3.18*	YES	ST07150-20FM
i	3xD	1-57/64	2-61/64	3-3/64	4-63/64	2-1/32	3/4	1/8	YES	ST03150-075F
	5xD	3-5/32	4-7/32	4-5/16	6-1/4	2-1/32	3/4	1/8	YES	ST05150-075F
	7xD	4-27/64	5-15/32	5-37/64	7-1/2	2-1/32	3/4	1/8	YES	ST07150-075F

*Thread to BSP and ISO 7-1

Connection Accessories

Insert Screws	Nylon Locking Screws	Insert Driver	Preset Torque Hand Driver	Replacement Tips	Admissible Tightening Torque*
7247-IP7-1	7247N-IP7-1	8IP-7	8IP-7TL	8IP-7B	84 N-cm (7.4 in-lbs)

*Tightening torques are calculated with a friction coefficient of $\mu = 0.14$ and develop 90% of ultimate yield strength

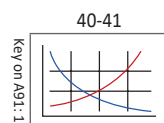

m = Metric (mm)
i = Imperial (in)

Inserts sold in multiples of 1 | Screws sold in multiples of 10

NOTICE: GEN3SYS XT Structural Steel holders are specifically designed to be used only with XT Pro ST or XT ST geometry inserts. Using other GEN3SYS XT Pro or XT insert geometries in these holders could lead to chip packing and tool failure. Contact Application Engineering for questions regarding proper use of tools.

GEN3SYS® XT Pro ST / GEN3SYS® XT ST Structural Steel Drilling System

16 Series | Diameter Range: 16.00mm - 16.99mm (0.6299" - 0.6692")

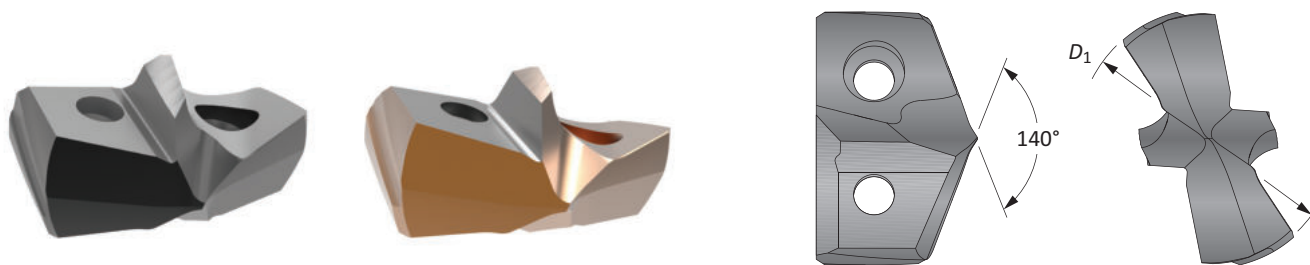

Inserts

Insert				
D_1 mm	D_1 inch	Fractional Equivalent	XT Pro ST Part No.	XT ST Part No.
16.00	0.6299	-	XTST16-16.00	7C216P-16ST

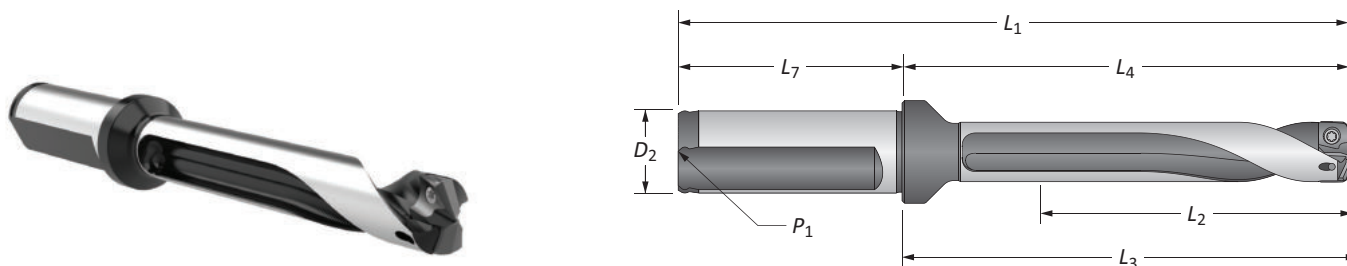

Holders

Length	Body				Shank				Flat	Part No.
	L_2	L_4	L_3	L_1	L_7	D_2	P_1			
m 3xD	51.0	81.3	84.2	131.3	50	20	3.18*	YES	ST03160-20FM	
m 5xD	84.9	115.3	118.2	165.3	50	20	3.18*	YES	ST05160-20FM	
m 7xD	118.9	149.3	152.2	199.3	50	20	3.18*	YES	ST07160-20FM	
i 3xD	3-1/64	3-13/64	3-5/16	5-15/64	2-1/32	3/4	1/8	YES	ST03160-075F	
i 5xD	3-23/64	4-17/32	4-21/32	6-9/16	2-1/32	3/4	1/8	YES	ST05160-075F	
i 7xD	4-11/16	5-7/8	5-63/64	7-29/32	2-1/32	3/4	1/8	YES	ST07160-075F	

*Thread to BSP and ISO 7-1

Connection Accessories

					Admissible Tightening Torque*
72556-IP8-1	72556N-IP8-1	8IP-8	8IP-8TL	8IP-8B	175 N-cm (15.5 in-lbs)

*Tightening torques are calculated with a friction coefficient of $\mu = 0.14$ and develop 90% of ultimate yield strength

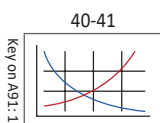

m = Metric (mm)
i = Imperial (in)

Inserts sold in multiples of 1 | Screws sold in multiples of 10



NOTICE: GEN3SYS XT Structural Steel holders are specifically designed to be used only with XT Pro ST or XT ST geometry inserts. Using other GEN3SYS XT Pro or XT insert geometries in these holders could lead to chip packing and tool failure. Contact Application Engineering for questions regarding proper use of tools.

GEN3SYS® XT Pro ST / GEN3SYS® XT ST Structural Steel Drilling System

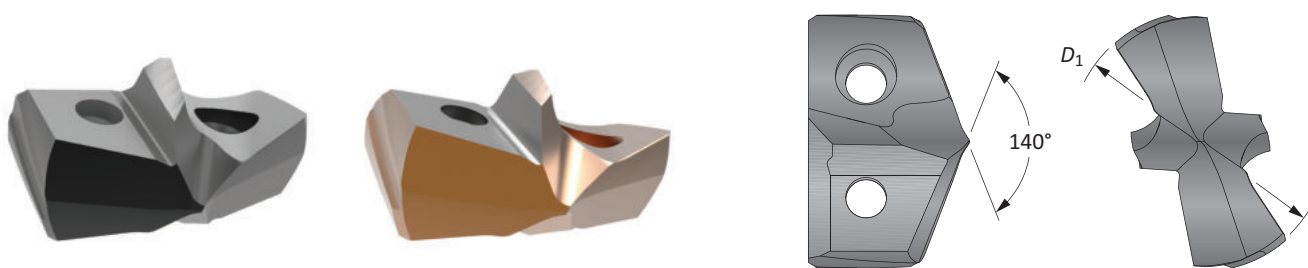
17 Series | Diameter Range: 17.00mm - 17.99mm (0.6693" - 0.7086")



Inserts

Insert				
D_1 mm	D_1 inch	Fractional Equivalent	XT Pro ST Part No.	XT ST Part No.
17.00	0.6693	-	XTST17-17.00	7C217P-17ST
17.46	0.6875	11/16	XTST17-17.46	7C217P-0022ST

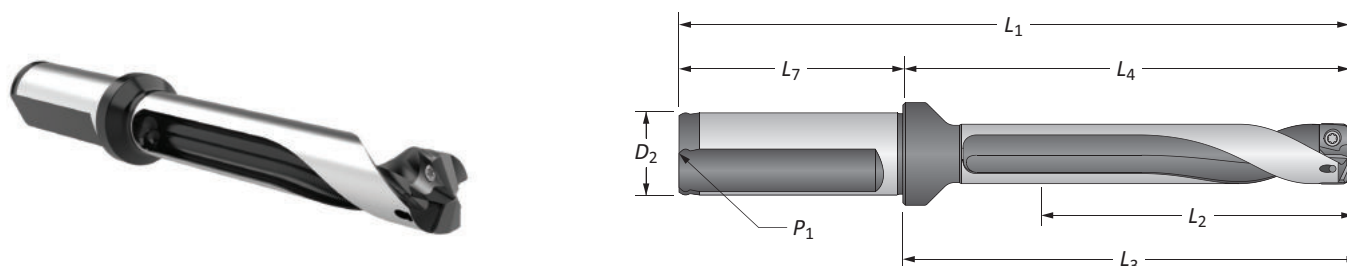



Holders

Length	Body				Shank				Flat	Part No.
	L_2	L_4	L_3	L_1	L_7	D_2	P_1			
m 3xD	54.0	84.1	87.0	134.1	50	20	3.18*	YES	ST03170-20FM	
m 5xD	89.9	120.0	122.9	170.0	50	20	3.18*	YES	ST05170-20FM	
m 7xD	125.9	156.0	158.9	206.0	50	20	3.18*	YES	ST07170-20FM	
i 3xD	2-1/8	3-5/16	3-27/64	5-11/32	2-1/32	3/4	1/8	YES	ST03170-075F	
i 5xD	3-35/64	4-23/32	4-27/32	6-3/4	2-1/32	3/4	1/8	YES	ST05170-075F	
i 7xD	4-31/32	6-9/64	6-1/4	8-11/64	2-1/32	3/4	1/8	YES	ST07170-075F	

*Thread to BSP and ISO 7-1

Connection Accessories

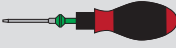
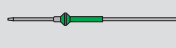
					Admissible Tightening Torque*
72567-IP8-1	72567N-IP8-1	8IP-8	8IP-8TL	8IP-8B	175 N-cm (15.5 in-lbs)

*Tightening torques are calculated with a friction coefficient of $\mu = 0.14$ and develop 90% of ultimate yield strength

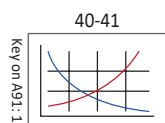

m = Metric (mm)
i = Imperial (in)

Inserts sold in multiples of 1 | Screws sold in multiples of 10

NOTICE: GEN3SYS XT Structural Steel holders are specifically designed to be used only with XT Pro ST or XT ST geometry inserts. Using other GEN3SYS XT Pro or XT insert geometries in these holders could lead to chip packing and tool failure. Contact Application Engineering for questions regarding proper use of tools.

GEN3SYS® XT Pro ST / GEN3SYS® XT ST Structural Steel Drilling System

18 Series | Diameter Range: 18.00mm - 19.99mm (0.7087" - 0.7873")

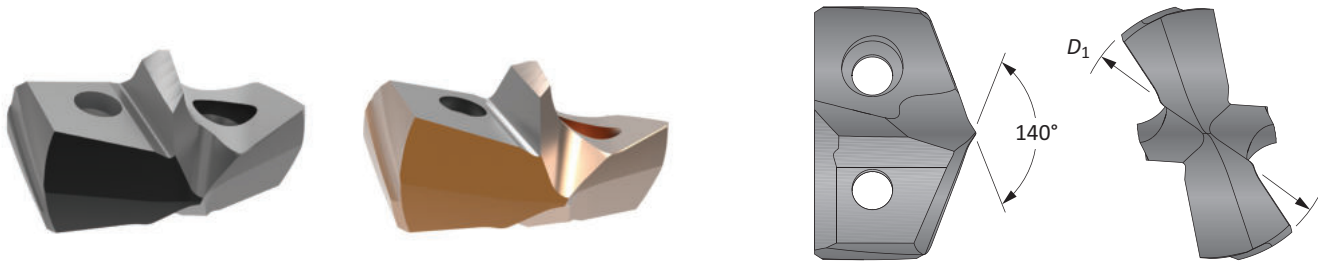

Inserts

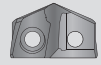
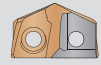
Insert				
D ₁ mm	D ₁ inch	Fractional Equivalent	XT Pro ST Part No.	XT ST Part No.
18.00	0.7087	-	XTST18-18.00	7C218P-18ST
19.00	0.7480	-	XTST18-19.00	7C218P-19ST

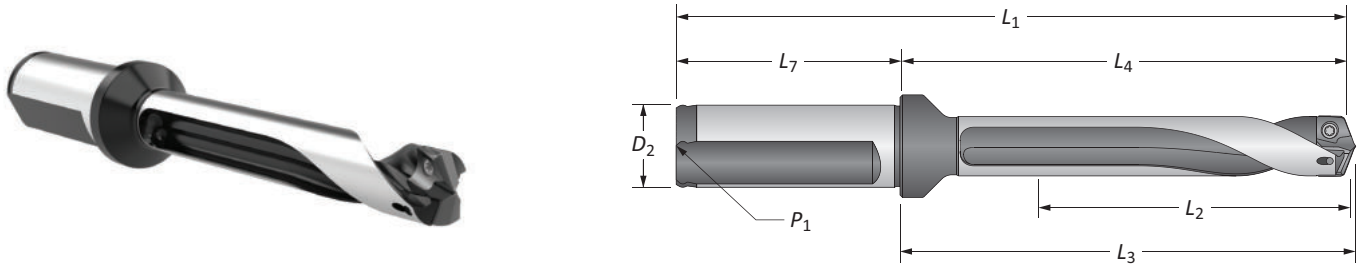





Holders

Length	Body				Shank				Flat	Part No.
	L ₂	L ₄	L ₃	L ₁	L ₇	D ₂	P ₁			
3xD	60.0	94.0	97.1	144.0	50	20	3.18*	YES	ST03180-20FM	
5xD	99.9	134.0	137.1	184.0	50	20	3.18*	YES	ST05180-20FM	
7xD	139.9	174.0	177.1	224.0	50	20	3.18*	YES	ST07180-20FM	
3xD	2-3/8	3-45/64	3-53/64	5-63/64	2-9/32	1	1/8	YES	ST03180-075F	
5xD	3-15/16	5-9/32	5-25/64	7-9/16	2-9/32	1	1/8	YES	ST05180-075F	
7xD	5-33/64	6-27/32	6-31/32	9-1/8	2-9/32	1	1/8	YES	ST07180-075F	

*Thread to BSP and ISO 7-1

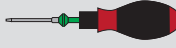
Connection Accessories

					Admissible Tightening Torque*
7375-IP9-1	7375N-IP9-1	8IP-9	8IP-9TL	8IP-9B	305 N-cm (27.0 in-lbs)

*Tightening torques are calculated with a friction coefficient of $\mu = 0.14$ and develop 90% of ultimate yield strength

40-41

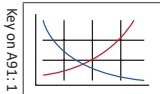

m = Metric (mm)
i = Imperial (in)

Inserts sold in multiples of 1 | Screws sold in multiples of 10



NOTICE: GEN3SYS XT Structural Steel holders are specifically designed to be used only with XT Pro ST or XT ST geometry inserts. Using other GEN3SYS XT Pro or XT insert geometries in these holders could lead to chip packing and tool failure. Contact Application Engineering for questions regarding proper use of tools.

GEN3SYS® XT Pro ST / GEN3SYS® XT ST Structural Steel Drilling System

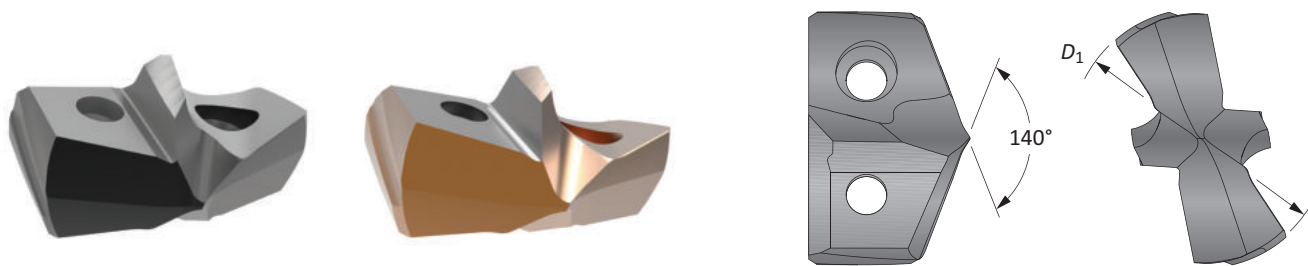
20 Series | Diameter Range: 20.00mm - 21.99mm (0.7874" - 0.8660")



Inserts

Insert				
D ₁ mm	D ₁ inch	Fractional Equivalent	XT Pro ST Part No.	XT ST Part No.
20.00	0.7874	–	XTST20-20.00	7C220P-20ST
20.64	0.8125	13/16	XTST20-20.64	7C220P-0026ST
21.00	0.8268	–	XTST20-21.00	7C220P-21ST
21.82	0.8594	55/64	XTST20-21.82	7C220P-0026ST

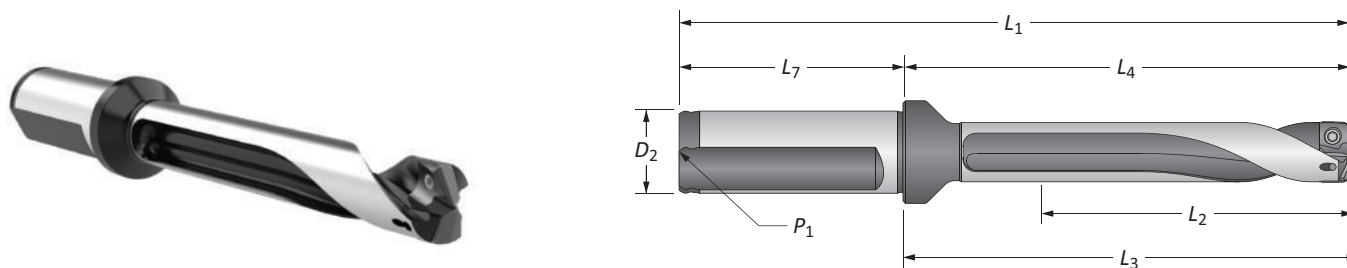





Holders

Length	Body				Shank				Flat	Part No.
	L ₂	L ₄	L ₃	L ₁	L ₇	D ₂	P ₁			
m 3xD	66.0	100.1	103.3	156.1	56	25	3.18*	YES	ST03200-25FM	
m 5xD	110.0	144.1	147.2	200.1	56	25	3.18*	YES	ST05200-25FM	
m 7xD	153.9	188.1	191.2	244.1	56	25	3.18*	YES	ST07200-25FM	
i 3xD	2-17/32	3-15/16	4-1/16	6-7/32	2-9/32	1	1/8	YES	ST03200-100F	
i 5xD	4-11/32	5-43/64	5-51/64	7-61/64	2-9/32	1	1/8	YES	ST05200-100F	
i 7xD	6-1/16	7-13/32	7-17/32	9-11/16	2-9/32	1	1/8	YES	ST07200-100F	

*Thread to BSP and ISO 7-1

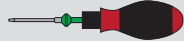
Connection Accessories

					Admissible Tightening Torque*
7375-IP9-1	7375N-IP9-1	8IP-9	8IP-9TL	8IP-9B	305 N-cm (27.0 in-lbs)

*Tightening torques are calculated with a friction coefficient of $\mu = 0.14$ and develop 90% of ultimate yield strength

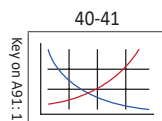

m = Metric (mm)
i = Imperial (in)

Inserts sold in multiples of 1 | Screws sold in multiples of 10



NOTICE: GEN3SYS XT Structural Steel holders are specifically designed to be used only with XT Pro ST or XT ST geometry inserts. Using other GEN3SYS XT Pro or XT insert geometries in these holders could lead to chip packing and tool failure. Contact Application Engineering for questions regarding proper use of tools.

GEN3SYS® XT Pro ST / GEN3SYS® XT ST Structural Steel Drilling System

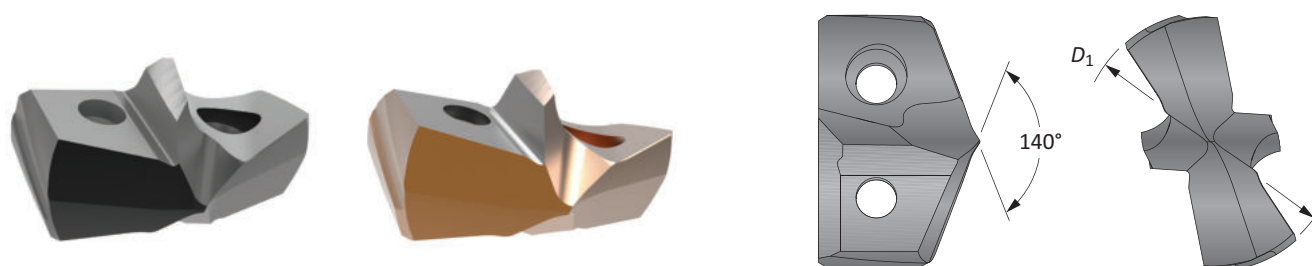
22 Series | Diameter Range: 22.00mm - 23.99mm (0.8661" - 0.9448")



Inserts

Insert				
D_1 mm	D_1 inch	Fractional Equivalent	XT Pro ST Part No.	XT ST Part No.
22.00	0.8661	-	XTST22-22.00	7C222P-22ST
22.23	0.8750	7/8	XTST22-22.23	7C222P-0028ST
23.00	0.9055	-	XTST22-23.00	7C222P-23ST
23.81	0.9375	15/16	XTST22-23.81	7C222P-0030ST

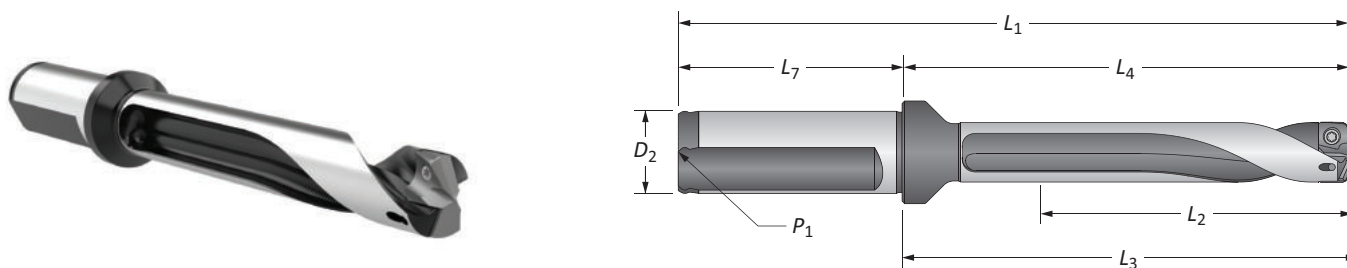





Holders

Length	Body				Shank				Flat	Part No.
	L_2	L_4	L_3	L_1	L_7	D_2	P_1			
3xD	72.0	105.3	108.7	161.3	56	25	3.18*	YES	ST03220-25FM	
3xD	72.0	105.3	108.7	161.3	56	25	3.18*	YES	ST03225-25FM**	
5xD	119.9	153.3	156.7	209.3	56	25	3.18*	YES	ST05220-25FM	
5xD	119.9	153.3	156.7	209.3	56	25	3.18*	YES	ST05225-25FM**	
7xD	167.9	201.3	204.7	257.3	56	25	3.18*	YES	ST07220-25FM	
7xD	167.9	201.3	204.7	257.3	56	25	3.18*	YES	ST07225-25FM**	
3xD	2-53/64	4-9/64	4-9/32	6-27/64	2-9/32	1	1/8	YES	ST03220-100F	
3xD	2-53/64	4-9/64	4-9/32	6-27/64	2-9/32	1	1/8	YES	ST03225-100F**	
5xD	4-23/32	6-1/32	6-11/64	8-5/16	2-9/32	1	1/8	YES	ST05220-100F	
5xD	4-23/32	6-1/32	6-11/64	8-5/16	2-9/32	1	1/8	YES	ST05225-100F**	
7xD	6-39/64	7-59/64	8-1/16	10-13/64	2-9/32	1	1/8	YES	ST07220-100F	
7xD	6-39/64	7-59/64	8-1/16	10-13/64	2-9/32	1	1/8	YES	ST07225-100F**	

*Thread to BSP and ISO 7-1 | **Oversized body holder (minimum drill diameter = 23mm)

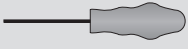
Connection Accessories

					Admissible Tightening Torque*
739-IP9-1	739N-IP9-1	8IP-9	8IP-9TL	8IP-9B	305 N-cm (27.0 in-lbs)

*Tightening torques are calculated with a friction coefficient of $\mu = 0.14$ and develop 90% of ultimate yield strength

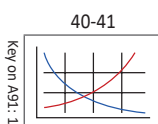

Ⓜ = Metric (mm)
Ⓢ = Imperial (in)

Inserts sold in multiples of 1 | Screws sold in multiples of 10

NOTICE: GEN3SYS XT Structural Steel holders are specifically designed to be used only with XT Pro ST or XT ST geometry inserts. Using other GEN3SYS XT Pro or XT insert geometries in these holders could lead to chip packing and tool failure. Contact Application Engineering for questions regarding proper use of tools.

GEN3SYS® XT Pro ST / GEN3SYS® XT ST Structural Steel Drilling System

24 Series | Diameter Range: 24.00mm - 25.99mm (0.9449" - 1.0235")

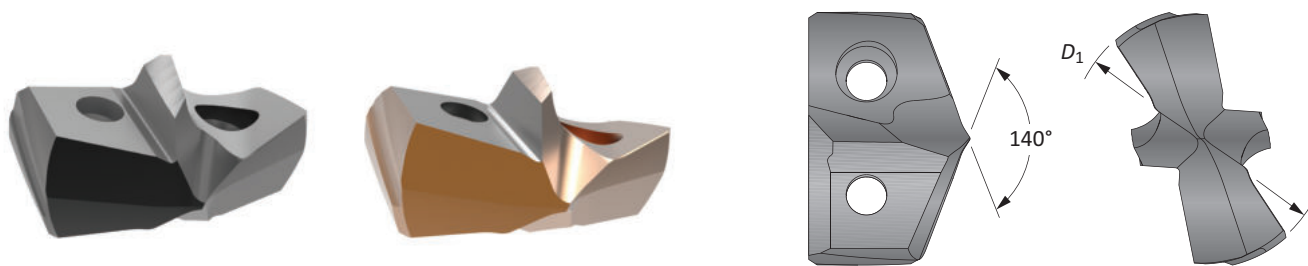

Inserts

Insert				
D_1 mm	D_1 inch	Fractional Equivalent	XT Pro ST Part No.	XT ST Part No.
24.00	0.9449	-	XTST24-24.00	7C224P-24ST
24.60	0.9685	-	XTST24-24.60	-
25.00	0.9843	-	-	7C224P-25ST
25.40	1.0000	1	XTST24-25.40	7C224P-0100ST
25.78	1.0150	-	XTST24-25.78	-

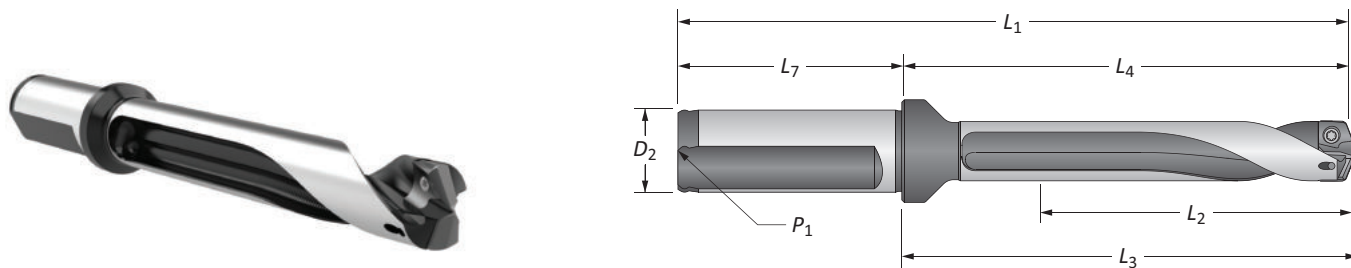

Holders

Length	Body				Shank				Flat	Part No.
	L_2	L_4	L_3	L_1	L_7	D_2	P_1			
m 3xD	78.0	113.8	117.3	169.8	56	25	3.18*	YES	ST03240-25FM	
m 5xD	129.9	165.8	169.2	221.8	56	25	3.18*	YES	ST05240-25FM	
m 7xD	181.9	217.8	221.2	273.8	56	25	3.18*	YES	ST07240-25FM	
i 3xD	3-5/64	4-31/64	4-5/8	6-49/64	2-9/32	1	1/8	YES	ST03240-100F	
i 5xD	5-1/8	6-17/32	6-21/32	8-13/16	2-9/32	1	1/8	YES	ST05240-100F	
i 7xD	7-11/64	8-37/64	8-45/64	10-55/64	2-9/32	1	1/8	YES	ST07240-100F	

*Thread to BSP and ISO 7-1

Connection Accessories

					Admissible Tightening Torque*
739-IP9-1	739N-IP9-1	8IP-9	8IP-9TL	8IP-9B	305 N-cm (27.0 in-lbs)

*Tightening torques are calculated with a friction coefficient of $\mu = 0.14$ and develop 90% of ultimate yield strength

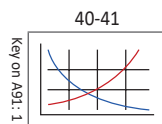

m = Metric (mm)
i = Imperial (in)

Inserts sold in multiples of 1 | Screws sold in multiples of 10

NOTICE: GEN3SYS XT Structural Steel holders are specifically designed to be used only with XT Pro ST or XT ST geometry inserts. Using other GEN3SYS XT Pro or XT insert geometries in these holders could lead to chip packing and tool failure. Contact Application Engineering for questions regarding proper use of tools.

GEN3SYS® XT Pro ST / GEN3SYS® XT ST Structural Steel Drilling System

26 Series | Diameter Range: 26.00mm - 28.99mm (1.0236" - 1.1416")

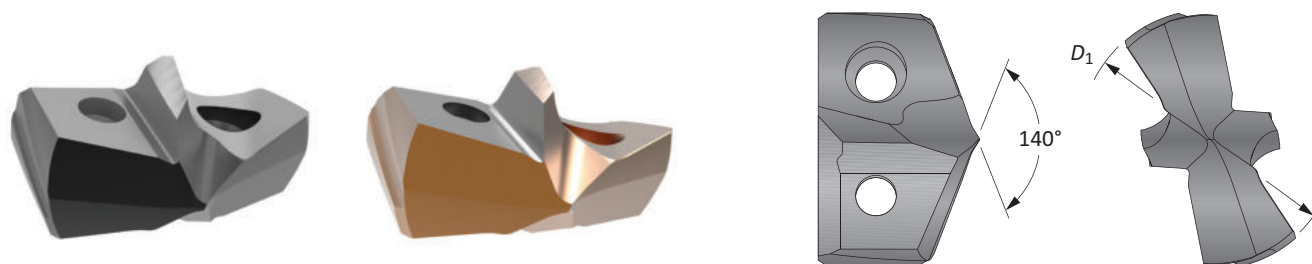

Inserts

Insert				
D ₁ mm	D ₁ inch	Fractional Equivalent	XT Pro ST Part No.	XT ST Part No.
26.00	1.0236	-	XTST26-26.00	7C226P-26ST
26.99	1.0625	1-1/16	XTST26-26.99	7C226P-0102ST
27.00	1.0630	-	XTST26-27.00	7C226P-27ST
28.00	1.1024	-	XTST26-28.00	7C226P-28ST
28.58	1.1250	1-1/8	XTST26-28.58	7C226P-0104ST

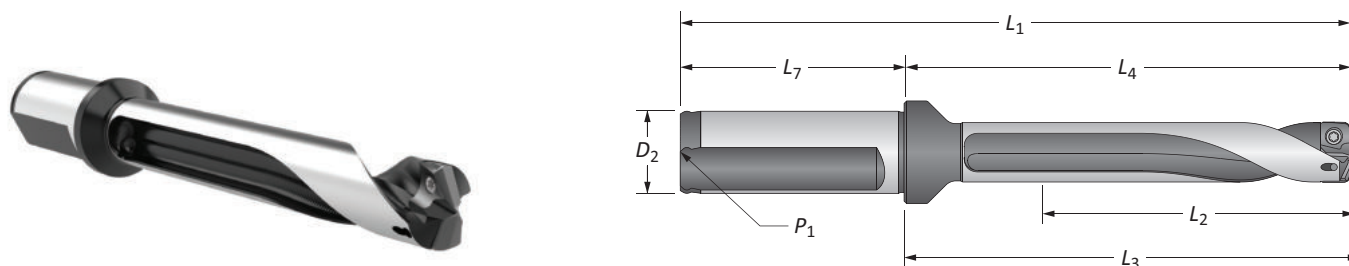

Holders

Length	Body				Shank				Flat	Part No.
	L ₂	L ₄	L ₃	L ₁	L ₇	D ₂	P ₁			
M 3xD	87.0	128.1	131.4	188.1	60	32	6.35*	YES	ST03260-32FM	
M 5xD	145.0	186.1	189.4	246.1	60	32	6.35*	YES	ST05260-32FM	
M 7xD	202.9	244.0	247.4	304.0	60	32	6.35*	YES	ST07260-32FM	
I 3xD	3-27/64	5-1/16	5-3/16	7-11/32	2-9/32	1-1/4	1/4	YES	ST03260-125F	
I 5xD	5-23/32	7-11/32	7-31/64	9-5/8	2-9/32	1-1/4	1/4	YES	ST05260-125F	
I 7xD	7-63/64	9-5/8	9-49/64	11-29/32	2-9/32	1-1/4	1/4	YES	ST07260-125F	

*Thread to BSP and ISO 7-1

Connection Accessories

					Admissible Tightening Torque*
7495-IP15-1	7495N-IP15-1	8IP-15	8IP-15TL	8IP-15B	690 N-cm (61.0 in-lbs)

*Tightening torques are calculated with a friction coefficient of $\mu = 0.14$ and develop 90% of ultimate yield strength

40-41

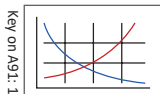

M = Metric (mm)
I = Imperial (in)

Inserts sold in multiples of 1 | Screws sold in multiples of 10

NOTICE: GEN3SYS XT Structural Steel holders are specifically designed to be used only with XT Pro ST or XT ST geometry inserts. Using other GEN3SYS XT Pro or XT insert geometries in these holders could lead to chip packing and tool failure. Contact Application Engineering for questions regarding proper use of tools.

GEN3SYS® XT Pro ST / GEN3SYS® XT ST Structural Steel Drilling System

29 Series | Diameter Range: 29.00mm - 31.99mm (1.1417" - 1.2597")

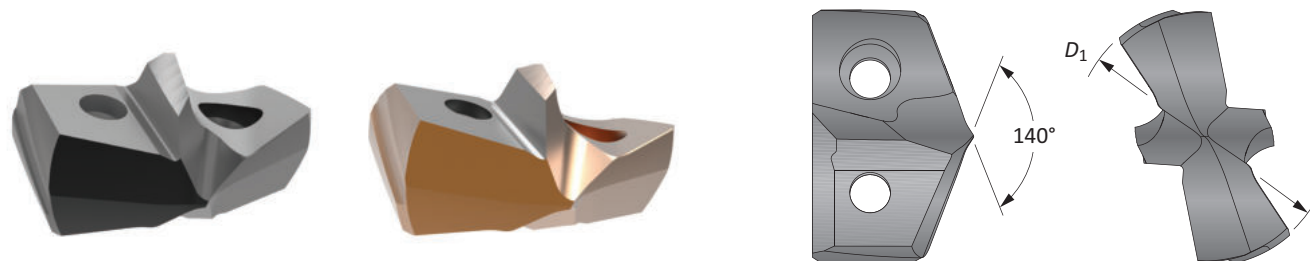

Inserts

D ₁ mm	Insert		XT Pro ST Part No.	XT ST Part No.
	D ₁ inch	Fractional Equivalent		
29.00	1.1417	-	XTST29-29.00	7C229P-29ST
30.00	1.1811	-	XTST29-30.00	7C229P-30ST
30.16	1.1875	1-3/16	XTST29-30.16	7C229P-0106ST
30.50	1.2007	-	-	7C229P-30.5ST
31.00	1.2205	-	XTST29-31.00	7C229P-31ST
31.75	1.2500	1-1/4	XTST29-31.75	7C229P-0108ST

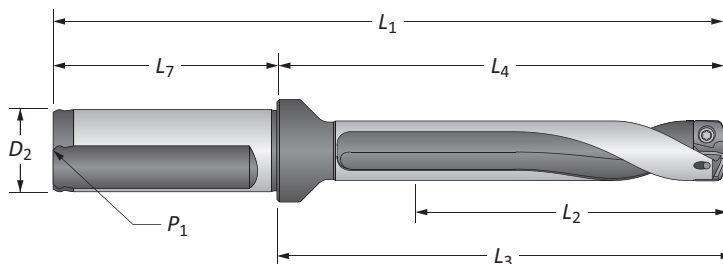

Holders

Length	Body				Shank				Flat	Part No.
	L ₂	L ₄	L ₃	L ₁	L ₇	D ₂	P ₁			
Ⓜ	3xD	96.0	136.2	139.7	196.2	60	32	6.35*	YES	ST03290-32FM
	5xD	159.9	200.1	203.7	260.1	60	32	6.35*	YES	ST05290-32FM
	7xD	223.9	264.1	267.7	324.1	60	32	6.35*	YES	ST07290-32FM
Ⓢ	3xD	3-25/32	5-3/8	5-33/64	7-21/32	2-9/32	1-1/4	1/4	YES	ST03290-125F
	5xD	6-19/64	7-29/32	8-3/64	10-3/16	2-9/32	1-1/4	1/4	YES	ST05290-125F
	7xD	8-13/16	10-27/64	10-9/16	12-45/64	2-9/32	1-1/4	1/4	YES	ST07290-125F

*Thread to BSP and ISO 7-1

Connection Accessories

Insert Screws	Nylon Locking Screws	Insert Driver	Preset Torque Hand Driver	Replacement Tips	Admissible Tightening Torque*
7495-IP15-1	7495N-IP15-1	8IP-15	8IP-15TL	8IP-15B	690 N-cm (61.0 in-lbs)

*Tightening torques are calculated with a friction coefficient of $\mu = 0.14$ and develop 90% of ultimate yield strength

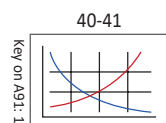

Ⓜ = Metric (mm)
Ⓢ = Imperial (in)



Inserts sold in multiples of 1 | Screws sold in multiples of 10

NOTICE: GEN3SYS XT Structural Steel holders are specifically designed to be used only with XT Pro ST or XT ST geometry inserts. Using other GEN3SYS XT Pro or XT insert geometries in these holders could lead to chip packing and tool failure. Contact Application Engineering for questions regarding proper use of tools.

GEN3SYS® XT Pro ST / GEN3SYS® XT ST Structural Steel Drilling System

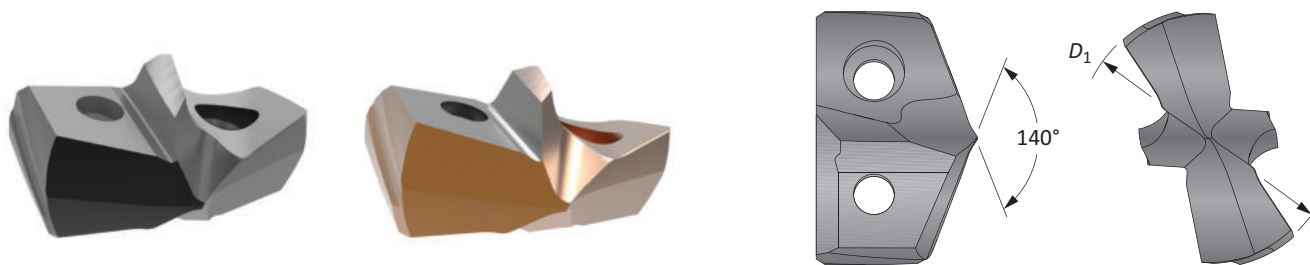
32 Series | Diameter Range: 32.00mm - 35.00mm (1.2598" - 1.3780")



Insert				
D ₁ mm	D ₁ inch	Fractional Equivalent	XT Pro ST Part No.	XT ST Part No.
32.00	1.2598	-	XTST32-32.00	7C232P-32ST
33.00	1.2992	-	XTST32-33.00	7C232P-33ST
33.34	1.3125	1-5/16	XTST32-33.34	7C232P-0110ST
34.00	1.3386	-	XTST32-34.00	7C232P-34ST
34.93	1.3750	1-3/8	XTST32-34.93	7C232P-0112ST

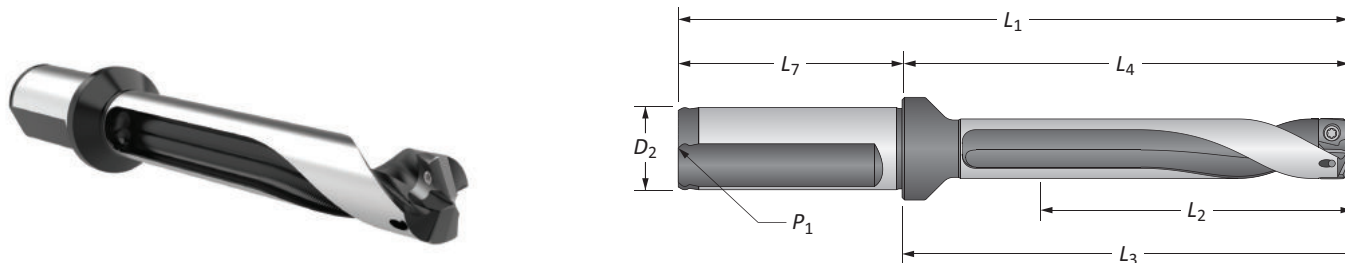





Holders

	Length	Body				Shank				Flat	Part No.
		L ₂	L ₄	L ₃	L ₁	L ₇	D ₂	P ₁			
m	3xD	105.0	157.7	162.0	217.7	60	32	6.35*	YES	ST03320-32FM	
	3xD	105.0	157.7	162.0	227.7	70	40	6.35*	YES	ST03320-40FM	
	5xD	175.0	227.7	232.0	287.7	60	32	6.35*	YES	ST05320-32FM	
	5xD	175.0	227.7	232.0	297.7	70	40	6.35*	YES	ST05320-40FM	
	7xD	244.9	297.7	302.2	357.7	60	32	6.35*	YES	ST07320-32FM	
	7xD	244.9	297.7	302.2	367.7	70	40	6.35*	YES	ST07320-40FM	
i	3xD	4-9/64	6-7/32	6-3/8	8-29/32	2-11/16	1-1/2	1/4	YES	ST03320-150F	
	5xD	6-59/64	8-31/32	9-1/8	11-21/32	2-11/16	1-1/2	1/4	YES	ST05320-150F	
	7xD	9-41/64	11-23/32	11-57/64	14-13/32	2-11/16	1-1/2	1/4	YES	ST07320-150F	

*Thread to BSP and ISO 7-1

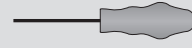
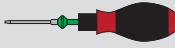
Connection Accessories

					Admissible Tightening Torque*
7495-IP15-1	7495N-IP15-1	8IP-15	8IP-15TL	8IP-15B	690 N-cm (61.0 in-lbs)

*Tightening torques are calculated with a friction coefficient of $\mu = 0.14$ and develop 90% of ultimate yield strength

40-41

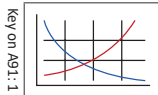

m = Metric (mm)
i = Imperial (in)

Inserts sold in multiples of 1 | Screws sold in multiples of 10

NOTICE: GEN3SYS XT Structural Steel holders are specifically designed to be used only with XT Pro ST or XT ST geometry inserts. Using other GEN3SYS XT Pro or XT insert geometries in these holders could lead to chip packing and tool failure. Contact Application Engineering for questions regarding proper use of tools.

Structural Steel Adaptors

DV45 & DV50 Adaptors

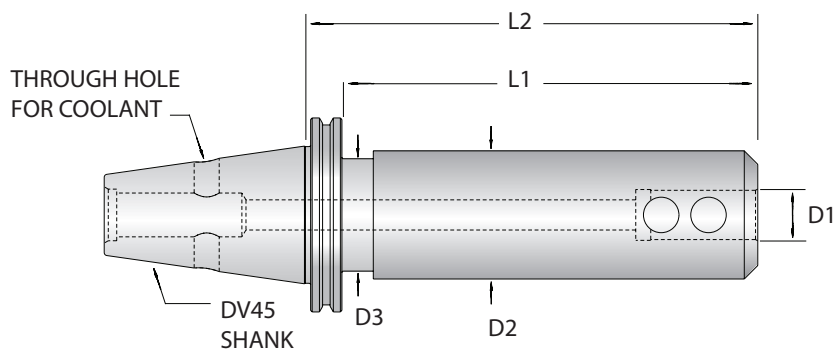

DV45 Adaptor

Item Number	Outer Taper	D1 Inner ϕ mm	D2 ϕ	D3 ϕ	L1	L2	Qty of Clamping Screws
AMDV45-EM20-120	DV45	20	52	57	101	120	1
AMDV45-EM25-120	DV45	25	65	57	101	120	2
AMDV45-EM32-120	DV45	32	78	57	101	120	2
AMDV45-EM20-230	DV45	20	52	57	211	230	1
AMDV45-EM25-230	DV45	25	65	57	211	230	2
AMDV45-EM32-230	DV45	32	78	57	211	230	2

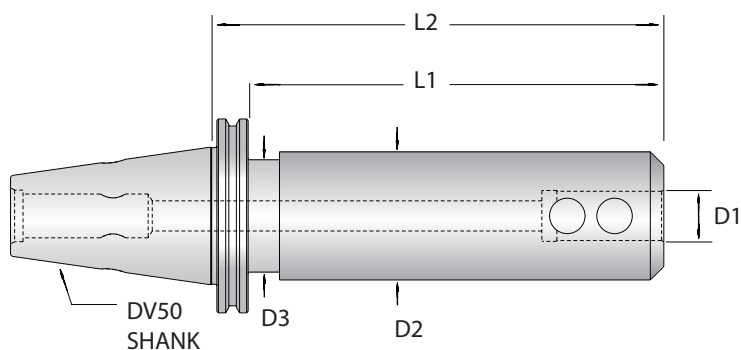

DV50 Adaptor

Item Number	Outer Taper	D1 Inner ϕ mm	D2 ϕ	D3 ϕ	L1	L2	Qty of Clamping Screws
AMDV45-EM50-120	DV50	50	100	69.858	100	120	2

T-A® Structural Steel Drilling System

GEN3SYS®XT ST and Pro ST

T-A® Structural Steel

Cutting Data & Guaranteed Application Forms

STRUCTURAL STEEL
ENHANCEMENTS
T-A® Original & GEN2 T-A®

GEN2 T-A® Insert

Available in AM200® Coating



High Efficiency (-HE)

- Improves performance
- Improves tool life
- Improves chip formation in structural steel materials

T-A® Original Inserts

Available in AM200® and TiAlN Coatings

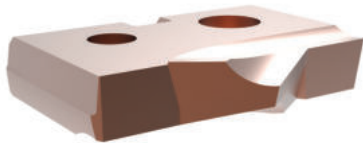

Thin Wall (-TW)

- Designed for drilling 6mm thick or less H-Beam or structural materials
- Increases hole diameter tolerance
- Improves hole roundness
- Decreases material deflection

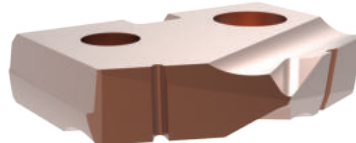

Notch Point® (-NP)

- Provides excellent self-centring characteristics
- Reduces bell mouth and tool lead-off
- Reduces axial thrust requirements

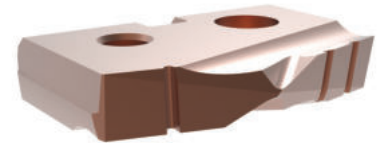

Structural Steel (-SS)

- Designed for drilling 6mm thick or thicker H-Beam or structural materials
- Reduces exit burrs
- Increases stability
- Lowers drilling forces
- Includes Notch Point® web geometry



Holder Anatomy

1. Morse Taper Shank
2. Coolant Inlet
3. Flute (straight or helical)
4. Built-up Body Diameter
5. Coolant Outlets



Straight Flute



Helical Flute

T-A® Drill Nomenclature

T-A® Drill Inserts

4	5	3	H	-	0115	-	HE
1	2	3	4		5		6

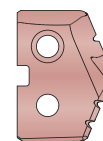

1. Insert	2. Material	3. Series	4. Coating	5. Diameter	6. Geometry
1 = T-A® Original 4 = GEN2 T-A®	5 = Super cobalt C1 = C1 (K35) carbide	0 = 0 series 1 = 1 series 2 = 2 series 3 = 3 series	H = AM200® A = TiAlN	13 = Metric .515 = Decimal 0017 = Inch	TW = Thin Wall NP = Notch Point® SS = Structural Steel HE = High Efficiency

Reference Key

Symbol	Attribute
D_1	Insert diameter
T_1	Insert thickness

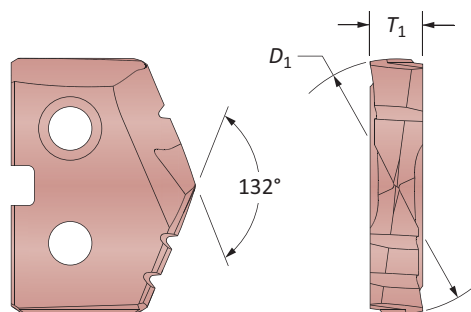

T-A® Drill Holders

2	40	20	S	-	004	IS	060
1	2	3	4		5	6	7



1. Holder	2. Length	3. Series	4. Flute
2 = T-A® holder	20 = Short 40 = Standard 50 = Extended 60 = Long	00 = 0 series 05 = 0.5 series 10 = 1 series 15 = 1.5 series 20 = 2 series 25 = 2.5 series 30 = 3 series	S = Straight H = Helical
5. Shank Designator	6. Shank Code	7. Minimum Insert Diameter	
003 = 3MT 004 = 4MT	IS = Imperial Morse taper structural steel	In increments of 0.4mm (1/64")	

Reference Key

Symbol	Attribute	Symbol	Attribute
D_1	Drill insert range	L_4	Flute length
L_1	Overall length	P_1	Rear pipe tap
L_2	Drill depth	P_2	Side pipe tap
L_3	Holder reference length	MT	Morse taper size
L_3^*	Holder reference length		

*If using Structural Steel holder with Notch Point®, GEN2 T-A®, or 150° Structural Steel T-A® drill insert geometry

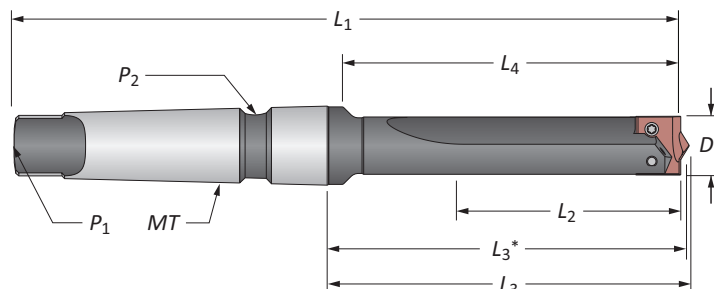

GEN3SYS®XT ST and Pro ST

T-A® Structural Steel

Cutting Data & Guaranteed Application Forms

T-A® Original Structural Steel Drill Inserts

0 Series | Diameter Range: 14.00mm - 17.46mm (0.5512" - 0.6875")

GENSYS®XT ST and Pro ST

T-A® Structural Steel

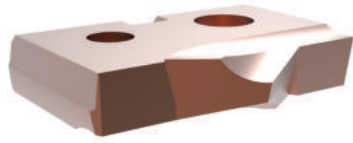

Thin Wall
For material up to 6mm thick

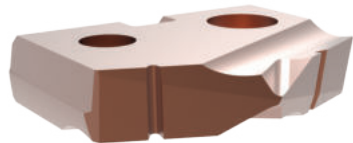
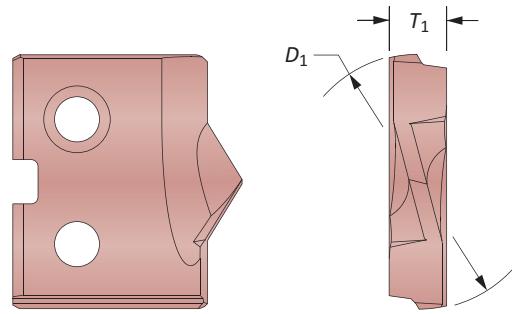

Notch Point®
For material over 6mm thick

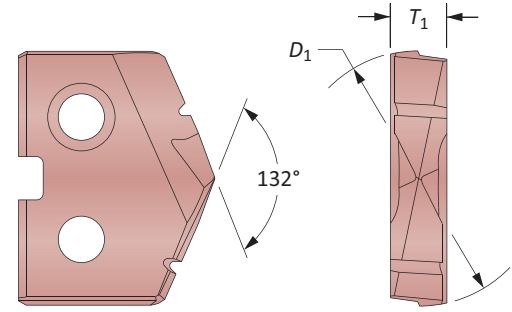

150° Structural Steel
For material over 6mm thick and for reduced exit burr

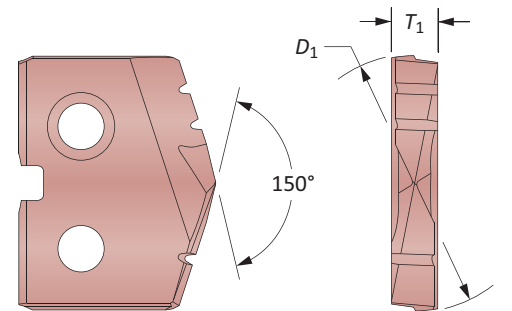

HSS Inserts – Super Cobalt

Series	Insert				Thin Wall		Notch Point		150° Structural Steel	
	Fractional Equivalent	D ₁ mm	D ₁ inch	T ₁	AM200 Part No.	TiAlN Part No.	AM200 Part No.	TiAlN Part No.	AM200 Part No.	TiAlN Part No.
0	–	14.00	0.5512	3.18	150H-14-TW	150A-14-TW	150H-14-NP	150A-14-NP	150H-14-SS	150A-14-SS
	9/16	14.29	0.5625	3.18	150H-0018-TW	150A-0018-TW	150H-0018-NP	150A-0018-NP	150H-0018-SS	150A-0018-SS
	5/8	15.88	0.6250	3.18	150H-0020-TW	150A-0020-TW	150H-0020-NP	150A-0020-NP	150H-0020-SS	150A-0020-SS
0.5	–	16.00	0.6299	3.18	150H-16-TW	150A-16-TW	150H-16-NP	150A-16-NP	150H-16-SS	150A-16-SS
	11/16	17.46	0.6875	3.18	150H-0022-TW	150A-0022-TW	150H-0022-NP	150A-0022-NP	150H-0022-SS	150A-0022-SS

Cutting Data & Guaranteed Application Forms

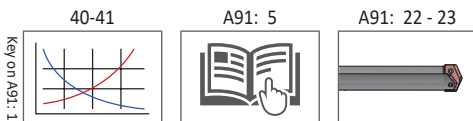

Inserts sold in multiples of 2

GEN2 T-A® Structural Steel Drill Inserts

0 Series | Diameter Range: 14.00mm - 17.46mm (0.5512" - 0.6875")

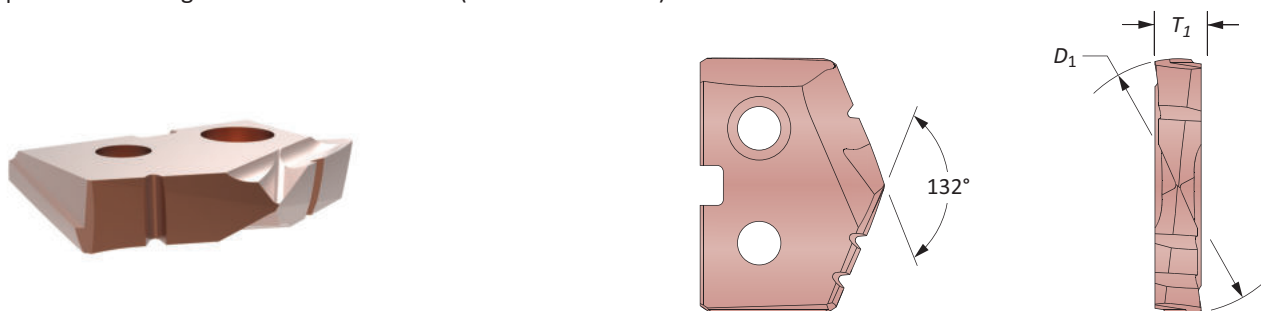

HSS Inserts – Super Cobalt | Carbide Inserts – C1 (K35)

Series	Fractional Equivalent	Insert			Part No.	
		D_1 mm	D_1 inch	T_1	Super Cobalt	C1 (K35)
0	–	14.00	0.5512	3.18	450H-14-HE	4C10H-14-HE
	9/16	14.29	0.5625	3.18	450H-0018-HE	4C10H-0018-HE
0.5	5/8	15.88	0.6250	3.18	450H-0020-HE	4C10H-0020-HE
	–	16.00	0.6299	3.18	450H-16-HE	4C10H-16-HE
	11/16	17.46	0.6875	3.18	450H-0022-HE	4C10H-0022-HE

GEN3SYS®XT ST and Pro ST

T-A® Structural Steel

Cutting Data & Guaranteed Application Forms

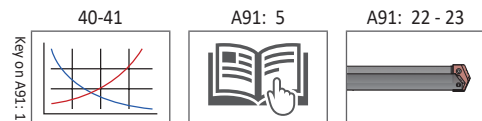

Inserts sold in multiples of 2

**T-A[®] Structural Steel Drill Insert Holders**

0 Series | Taper Shank

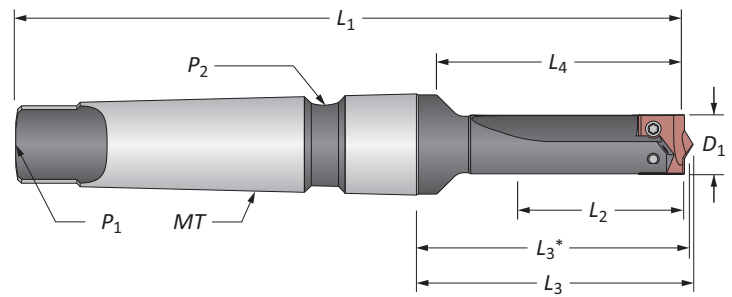
**Straight Flute #3 Morse Taper**

Series	Length	D ₁	Body					Shank			Part No.	
			L ₂	L ₄	L ₃	L ₃ *	L ₁	MT	P ₁	P ₂		
m	0	Short	14	35	56	64.7	63.1	154	#3	TTC	TSC	22000S-003IS036
		Short	16	35	56	64.7	63.1	154	#3	TTC	TSC	22000S-003IS040
		Short	17.46	35	56	64.7	63.1	154	#3	TTC	TSC	22000S-003IS044
i	0	Short	9/16	1-3/8	2-3/16	2-35/64	2-31/64	6-1/16	#3	TTC	TSC	22000S-003IS036
		Short	5/8	1-3/8	2-3/16	2-35/64	2-31/64	6-1/16	#3	TTC	TSC	22005S-003IS040
		Short	11/16	1-3/8	2-3/16	2-35/64	2-31/64	6-1/16	#3	TTC	TSC	22005S-003IS044

*If using Structural Steel holder with Notch Point[®], GEN2 T-A[®], or 150° Structural Steel T-A[®] drill insert geometry**Connection Accessories**

Series	Insert Screws	Nylon Locking Screws	Insert Driver	Preset Torque Hand Driver	Replacement Tips	Admissible Tightening Torque*
0	72556-IP8-1	72556N-IP8-1	8IP-8	8IP-8TL	8IP-8B	175 N-cm (15.5 in-lbs)
0.5	72567-IP8-1	72567N-IP8-1	8IP-8	8IP-8TL	8IP-8B	175 N-cm (15.5 in-lbs)

*Tightening torques are calculated with a friction coefficient of $\mu = 0.14$ and develop 90% of ultimate yield strength

A91: 5

A91: 20 - 21

Key on A91: 1

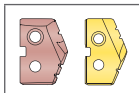

m = Metric (mm)

i = Imperial (in)

Screws sold in multiples of 10

T-A® Structural Steel Drill Insert Holders

0 Series | Taper Shank

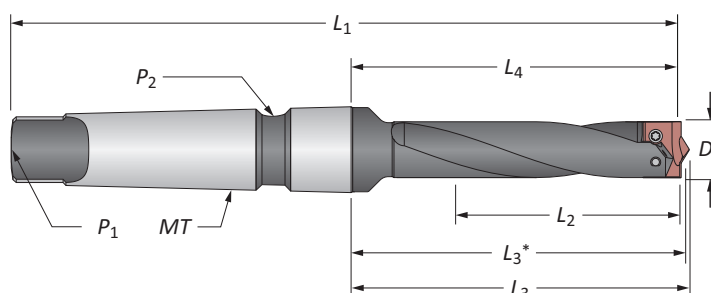

Helical Flute #3 Morse Taper

Series	Length	D ₁	Body					Shank			Part No.
			L ₂	L ₄	L ₃	L ₃ *	L ₁	MT	P ₁	P ₂	
0	Standard	14	64	84	93.3	91.7	183	#3	TTC	TSC	24000H-003IS036
	Extended	14	165	240	248.8	243.7	338	#3	TTC	TSC	25000H-003IS036
0.5	Standard	16	64	84	93.3	91.7	183	#3	TTC	TSC	24005H-003IS040
	Extended	17.46	165	240	248.8	243.7	338	#3	TTC	TSC	25005H-003IS044
0	Standard	9/16	2-1/2	3-5/16	3-43/64	3-39/64	7-3/16	#3	TTC	TSC	24000H-003IS036
	Extended	9/16	6-1/2	9-7/16	9-51/64	9-19/32	13-5/64	#3	TTC	TSC	25000H-003IS036
0.5	Standard	5/8	2-1/2	3-5/16	3-43/64	3-39/64	7-3/16	#3	TTC	TSC	24005H-003IS040
	Extended	11/16	6-1/2	9-7/16	9-51/64	9-19/32	13-5/64	#3	TTC	TSC	25005H-003IS044

*If using Structural Steel holder with Notch Point®, GEN2 T-A®, or 150° Structural Steel T-A® drill insert geometry

Ⓜ = Metric (mm)

Ⓜ = Imperial (in)

Screws sold in multiples of 10

⚠ WARNING Refer to Speed and Feed charts for recommended adjustments to speeds and feeds. Refer to page A91: 35 for deep hole drilling guidelines in this section of the catalogue. Visit www.alliedmachine.com/deepholeguidelines.aspx for the most up-to-date information and procedures. Factory technical assistance is available for your specific applications through our Application Engineering Team.

T-A® Original Structural Steel Drill Inserts

1 Series | Diameter Range: 18.00mm - 24.00mm (0.7087" - 0.9449")

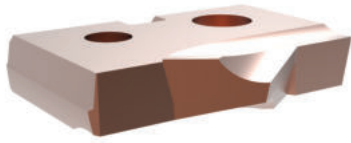

Thin Wall
For material up to 6mm thick

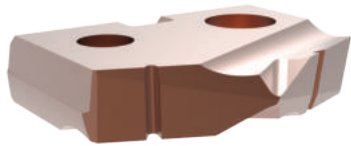
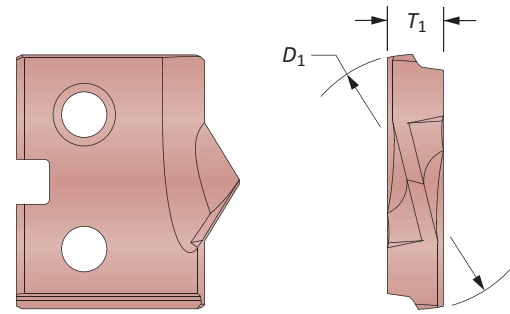

Notch Point®
For material over 6mm thick

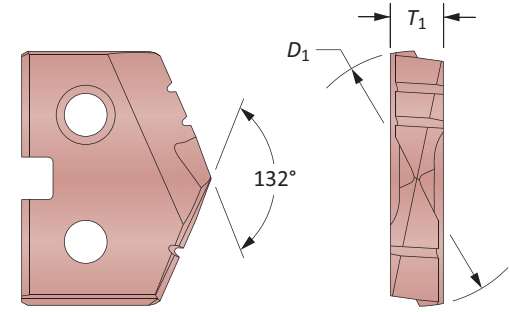

150° Structural Steel
For material over 6mm thick and for reduced exit burr

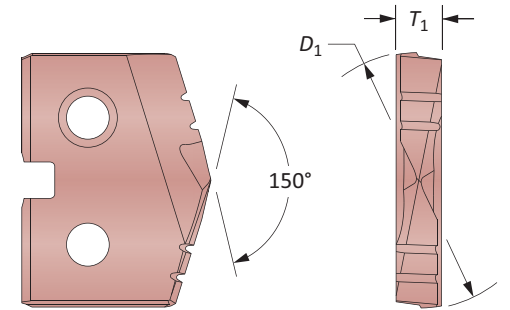

HSS Inserts – Super Cobalt

Series	Insert				Thin Wall		Notch Point		150° Structural Steel	
	Fractional Equivalent	D ₁ mm	D ₁ inch	T ₁	AM200 Part No.	TiAlN Part No.	AM200 Part No.	TiAlN Part No.	AM200 Part No.	TiAlN Part No.
1	-	18.00	0.7087	3.97	151H-18-TW	151A-18-TW	151H-18-NP	151A-18-NP	151H-18-SS	151A-18-SS
	13/16	20.64	0.8125	3.97	151H-0026-TW	151A-0026-TW	151H-0026-NP	151A-0026-NP	151H-0026-SS	151A-0026-SS
	-	21.00	0.8268	3.97	151H-21-TW	151A-21-TW	151H-21-NP	151A-21-NP	151H-21-SS	151A-21-SS
1.5	-	22.00	0.8661	3.97	151H-22-TW	151A-22-TW	151H-22-NP	151A-22-NP	151H-22-SS	151A-22-SS
	7/8	22.23	0.8750	3.97	151H-0028-TW	151A-0028-TW	151H-0028-NP	151A-0028-NP	151H-0028-SS	151A-0028-SS
	15/16	23.81	0.9375	3.97	151H-0030-TW	151A-0030-TW	151H-0030-NP	151A-0030-NP	151H-0030-SS	151A-0030-SS
	-	24.00	0.9449	3.97	151H-24-TW	151A-24-TW	151H-24-NP	151A-24-NP	151H-24-SS	151A-24-SS

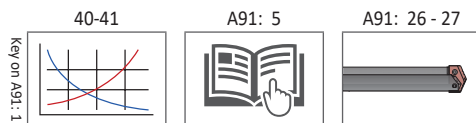

Inserts sold in multiples of 2

GEN2 T-A® Structural Steel Drill Inserts

1 Series | Diameter Range: 18.00mm - 24.00mm (0.7087" - 0.9449")

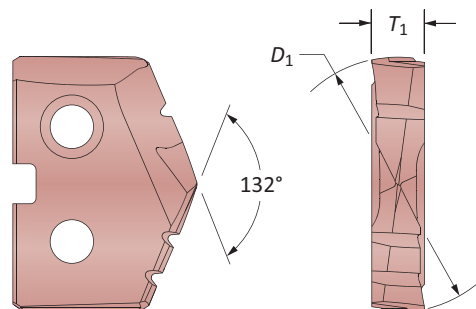

HSS Inserts – Super Cobalt | Carbide Inserts – C1 (K35)

Series	Fractional Equivalent	Insert			Part No.	
		D_1 mm	D_1 inch	T_1	Super Cobalt	C1 (K35)
1	–	18.00	0.7087	3.97	451H-18-HE	4C11H-18-HE
	13/16	20.64	0.8125	3.97	451H-0026-HE	4C11H-0026-HE
	–	21.00	0.8268	3.97	451H-21-HE	4C11H-21-HE
	–	22.00	0.8661	3.97	451H-22-HE	4C11H-22-HE
1.5	7/8	22.23	0.8750	3.97	451H-0028-HE	4C11H-0028-HE
	15/16	23.81	0.9375	3.97	451H-0030-HE	4C11H-0030-HE
	–	24.00	0.9449	3.97	451H-24-HE	4C11H-24-HE

40-41

Key on A91: 1

A91: 5

A91: 26 - 27

Inserts sold in multiples of 2

T-A® Structural Steel Drill Insert Holders

1 Series | Taper Shank

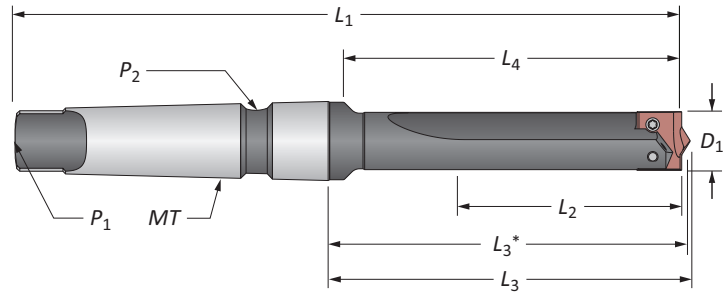

Straight Flute #3 Morse Taper

Series	Length	D ₁	Body					Shank			Part No.	
			L ₂	L ₄	L ₃	L ₃ *	L ₁	MT	P ₁	P ₂		
m	1	Short	18	70	98	108.4	106.8	197	#3	TTC	TSC	22010S-003IS045
		Short	20.64	70	98	108.4	106.8	197	#3	TTC	TSC	22010S-003IS052
m	1.5	Short	22	70	98	108.4	106.8	197	#3	TTC	TSC	22015S-003IS056
		Short	24	70	98	108.4	106.8	197	#3	TTC	TSC	22015S-003IS060
i	1	Short	18mm	2-3/4	3-7/8	4-17/64	4-13/64	7-3/4	#3	TTC	TSC	22010S-003IS045
		Short	13/16	2-3/4	3-7/8	4-17/64	4-13/64	7-3/4	#3	TTC	TSC	22010S-003IS052
i	1.5	Short	7/8	2-3/4	3-7/8	4-17/64	4-13/64	7-3/4	#3	TTC	TSC	22015S-003IS056
		Short	15/16	2-3/4	3-7/8	4-17/64	4-13/64	7-3/4	#3	TTC	TSC	22015S-003IS060

*If using Structural Steel holder with Notch Point®, GEN2 T-A®, or 150° Structural Steel T-A® drill insert geometry

Straight Flute #4 Morse Taper

Series	Length	D ₁	Body					Shank			Part No.	
			L ₂	L ₄	L ₃	L ₃ *	L ₁	MT	P ₁	P ₂		
m	1	Short	18	70	98	109.9	108.3	222	#4	TTC	TSC	22010S-004IS045
		Short	20.64	70	98	109.9	108.3	222	#4	TTC	TSC	22010S-004IS052
m	1.5	Short	22	70	98	109.9	108.3	222	#4	TTC	TSC	22015S-004IS056
		Short	24	70	98	109.9	108.3	222	#4	TTC	TSC	22015S-004IS060
i	1	Short	18mm	2-3/4	3-7/8	4-21/64	4-17/64	8-3/4	#4	TTC	TSC	22010S-004IS045
		Short	13/16	2-3/4	3-7/8	4-21/64	4-17/64	8-3/4	#4	TTC	TSC	22010S-004IS052
i	1.5	Short	7/8	2-3/4	3-7/8	4-21/64	4-17/64	8-3/4	#4	TTC	TSC	22015S-004IS056
		Short	15/16	2-3/4	3-7/8	4-21/64	4-17/64	8-3/4	#4	TTC	TSC	22015S-004IS060

*If using Structural Steel holder with Notch Point®, GEN2 T-A®, or 150° Structural Steel T-A® drill insert geometry

Connection Accessories

Series	Insert Screws	Nylon Locking Screws	Insert Driver	Preset Torque Hand Driver	Replacement Tips	Admissible Tightening Torque*
1	7375-IP9-1	7375N-IP9-1	8IP-9	8IP-9TL	8IP-9B	305 N-cm (27.0 in-lbs)
1.5	739-IP9-1	739N-IP9-1	8IP-9	8IP-9TL	8IP-9B	305 N-cm (27.0 in-lbs)

*Tightening torques are calculated with a friction coefficient of $\mu = 0.14$ and develop 90% of ultimate yield strength

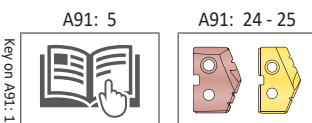

m = Metric (mm)
i = Imperial (in)
Screws sold in multiples of 10

T-A® Structural Steel Drill Insert Holders

1 Series | Taper Shank

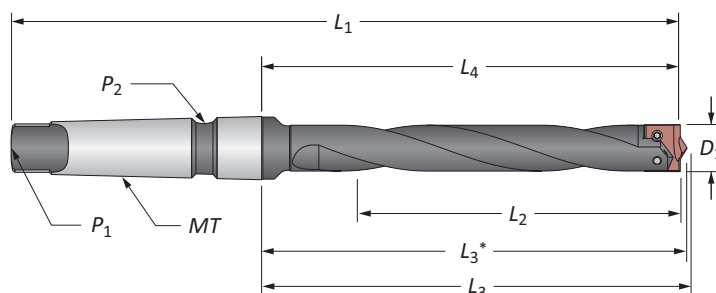

Helical Flute #3 Morse Taper

Series	Length	D ₁	Body					Shank			Part No.	
			L ₂	L ₄	L ₃	L ₃ *	L ₁	MT	P ₁	P ₂		
m	1	Standard	18	121	149	159.2	157.6	248	#3	TTC	TSC	24010H-003IS045
		Standard	20.64	121	149	159.2	157.6	248	#3	TTC	TSC	24010H-003IS052
	Extended	18	165	237	247.3	241.3	336	#3	TTC	TSC	⚠ 25010H-003IS045	
	Extended	22	165	237	247.3	241.3	336	#3	TTC	TSC	⚠ 25010H-003IS052	
1.5	Standard	22	121	149	159.2	157.6	248	#3	TTC	TSC	24015H-003IS056	
	Standard	24	121	149	159.2	157.6	248	#3	TTC	TSC	24015H-003IS060	
	Extended	24	165	237	247.3	234.5	336	#3	TTC	TSC	⚠ 25015H-003IS060	
i	1	Standard	18mm	4-3/4	5-7/8	6-17/64	6-13/64	9-3/4	#3	TTC	TSC	24010H-003IS045
		Standard	13/16	4-3/4	5-7/8	6-17/64	6-13/64	9-3/4	#3	TTC	TSC	24010H-003IS052
		Extended	18mm	6-1/2	9-11/32	9-47/64	9-1/2	13-7/32	#3	TTC	TSC	⚠ 25010H-003IS045
		Extended	13/16	6-1/2	9-11/32	9-47/64	9-1/2	13-7/32	#3	TTC	TSC	⚠ 25010H-003IS052
	1.5	Standard	7/8	4-3/4	5-7/8	6-17/64	6-13/64	9-3/4	#3	TTC	TSC	24015H-003IS056
		Standard	15/16	4-3/4	5-7/8	6-17/64	6-13/64	9-3/4	#3	TTC	TSC	24015H-003IS060
		Extended	15/16	6-1/2	9-11/32	9-47/64	9-15/32	13-7/32	#3	TTC	TSC	⚠ 25015H-003IS060

*If using Structural Steel holder with Notch Point®, GEN2 T-A®, or 150° Structural Steel T-A® drill insert geometry

Helical Flute #4 Morse Taper

Series	Length	D ₁	Body					Shank			Part No.	
			L ₂	L ₄	L ₃	L ₃ *	L ₁	MT	P ₁	P ₂		
m	1	Standard	18	121	149	159.2	157.6	248	#4	TTC	TSC	24010H-004IS045
		Standard	20.64	121	149	159.2	157.6	248	#4	TTC	TSC	24010H-004IS056
	Extended	20.64	165	237	247.3	241.3	336	#4	TTC	TSC	⚠ 25010H-004IS056	
	Long	20.64	165	237	247.3	241.3	336	#4	TTC	TSC	⚠ 26010H-004IS056	
1.5	Standard	22	121	149	159.2	157.6	248	#4	TTC	TSC	24015H-004IS056	
	Standard	24	121	149	159.2	157.6	248	#4	TTC	TSC	24015H-004IS060	
	Extended	24	165	149	159.2	157.6	248	#4	TTC	TSC	⚠ 25015H-004IS060	
	Long	24	165	237	247.3	234.5	336	#4	TTC	TSC	⚠ 26015H-004IS060	
i	1	Standard	18mm	4-3/4	5-7/8	6-21/64	6-17/64	10-3/4	#4	TTC	TSC	24010H-004IS045
		Standard	13/16	4-3/4	5-7/8	6-21/64	6-17/64	10-3/4	#4	TTC	TSC	24010H-004IS052
		Extended	13/16	6-1/2	9-9/32	9-47/64	9-43/64	14-5/32	#4	TTC	TSC	⚠ 25010H-004IS052
		Long	13/16	6-1/2	15-25/32	16-15/64	16-11/64	20-21/32	#4	TTC	TSC	⚠ 26010H-004IS052
	1.5	Standard	7/8	4-3/4	5-7/8	6-21/64	6-17/64	10-3/4	#4	TTC	TSC	24015H-004IS056
		Standard	15/16	4-3/4	5-7/8	6-21/64	6-17/64	10-3/4	#4	TTC	TSC	24015H-004IS060
		Extended	15/16	6-1/2	9-9/32	9-47/64	9-43/64	14-5/32	#4	TTC	TSC	⚠ 25015H-004IS060
		Long	15/16	6-1/2	15-13/16	16-17/64	16-13/64	20-11/16	#4	TTC	TSC	⚠ 26015H-004IS060

*If using Structural Steel holder with Notch Point®, GEN2 T-A®, or 150° Structural Steel T-A® drill insert geometry

m = Metric (mm)
 i = Imperial (in)
 Screws sold in multiples of 10

⚠ WARNING Refer to Speed and Feed charts for recommended adjustments to speeds and feeds. Refer to page A91: 35 for deep hole drilling guidelines in this section of the catalogue. Visit www.alliedmachine.com/deepholeguidelines.aspx for the most up-to-date information and procedures. Factory technical assistance is available for your specific applications through our Application Engineering Team.

T-A® Original Structural Steel Drill Inserts

2 Series | Diameter Range: 25.40mm - 34.93mm (1.0000" - 1.3750")



Thin Wall
For material up to 6mm thick

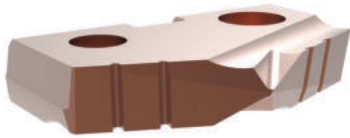
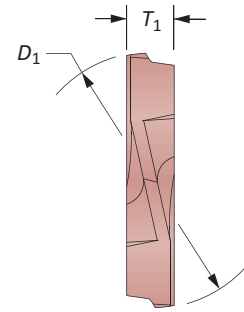
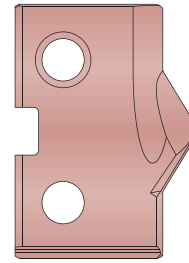

Notch Point®
For material over 6mm thick

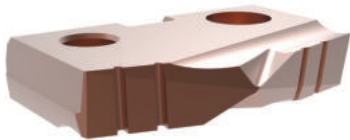
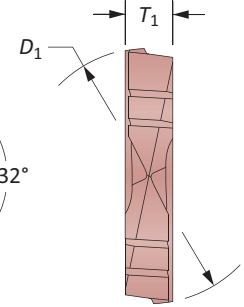
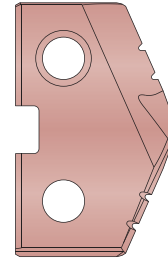

150° Structural Steel
For material over 6mm thick and for reduced exit burr

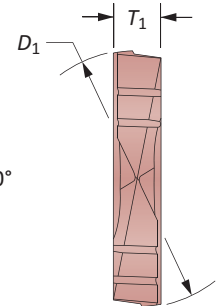
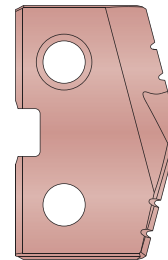

HSS Inserts – Super Cobalt

Series	Insert				Thin Wall		Notch Point		150° Structural Steel	
	Fractional Equivalent	D ₁ mm	D ₁ inch	T ₁	AM200 Part No.	TiAlN Part No.	AM200 Part No.	TiAlN Part No.	AM200 Part No.	TiAlN Part No.
2	1	25.40	1.0000	4.76	152H-0100-TW	152A-0100-TW	152H-0100-NP	152A-0100-NP	152H-0100-SS	152A-0100-SS
	-	26.00	1.0236	4.76	152H-26-TW	152A-26-TW	152H-26-NP	152A-26-NP	152H-26-SS	152A-26-SS
	1-1/16	26.99	1.0625	4.76	152H-0102-TW	152A-0102-TW	152H-0102-NP	152A-0102-NP	152H-0102-SS	152A-0102-SS
	-	27.00	1.0630	4.76	152H-27-TW	152A-27-TW	152H-27-NP	152A-27-NP	152H-27-SS	152A-27-SS
2.5	1-1/8	28.58	1.1250	4.76	152H-0104-TW	152A-0104-TW	152H-0104-NP	152A-0104-NP	152H-0104-SS	152A-0104-SS
	1-3/16	30.16	1.1875	4.76	152H-0106-TW	152A-0106-TW	152H-0106-NP	152A-0106-NP	152H-0106-SS	152A-0106-SS
	-	31.00	1.2205	4.76	152H-31-TW	152A-31-TW	152H-31-NP	152A-31-NP	152H-31-SS	152A-31-SS
	1-1/4	31.75	1.2500	4.76	152H-0108-TW	152A-0108-TW	152H-0108-NP	152A-0108-NP	152H-0108-SS	152A-0108-SS
	-	33.00	1.2992	4.76	152H-33-TW	152A-33-TW	152H-33-NP	152A-33-NP	152H-33-SS	152A-33-SS
	1-5/16	33.34	1.3125	4.76	152H-0110-TW	152A-0110-TW	152H-0110-NP	152A-0110-NP	152H-0110-SS	152A-0110-SS
1-3/8	34.93	1.3750	4.76	152H-0112-TW	152A-0112-TW	152H-0112-NP	152A-0112-NP	152H-0112-SS	152A-0112-SS	

40-41 A91: 5 A91: 30 - 31

Inserts sold in multiples of 2

GEN2 T-A® Structural Steel Drill Inserts

2 Series | Diameter Range: 25.40mm - 34.93mm (1.0000" - 1.3750")

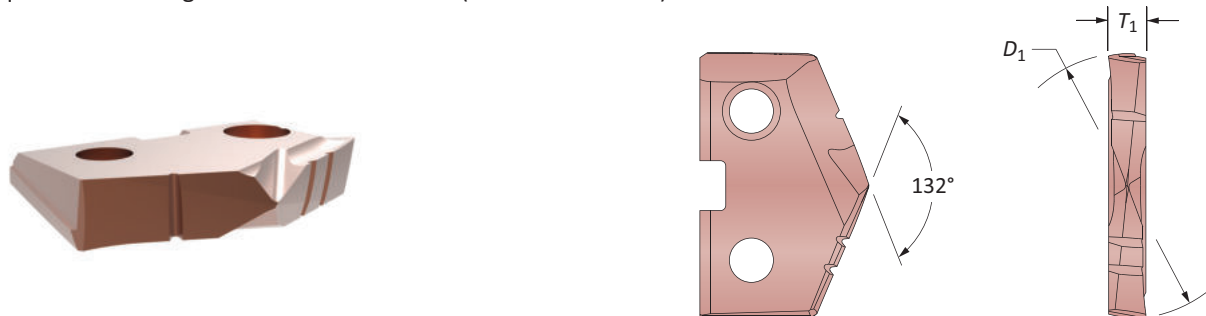

HSS Inserts – Super Cobalt | Carbide Inserts – C1 (K35)

Series	Fractional Equivalent	Insert			Part No.	
		D ₁ mm	D ₁ inch	T ₁	Super Cobalt	C1 (K35)
2	1	25.40	1.0000	4.76	452H-0100-HE	4C12H-0100-HE
	–	26.00	1.0236	4.76	452H-26-HE	4C12H-26-HE
	1-1/16	26.99	1.0625	4.76	452H-0102-HE	4C12H-0102-HE
	–	27.00	1.0630	4.76	452H-27-HE	4C12H-27-HE
	1-1/8	28.58	1.1250	3/16	452H-0104-HE	4C12H-0104-HE
2.5	1-3/16	30.16	1.1875	4.76	452H-0106-HE	4C12H-0106-HE
	–	31.00	1.2205	4.76	452H-31-HE	4C12H-31-HE
	1-1/4	31.75	1.2500	4.76	452H-0108-HE	4C12H-0108-HE
	–	33.00	1.2992	4.76	452H-33-HE	4C12H-33-HE
	1-5/16	33.34	1.3125	4.76	452H-0110-HE	4C12H-0110-HE
	1-3/8	34.93	1.3750	4.76	452H-0112-HE	4C12H-0112-HE

GEN3SYS®XT ST and Pro ST

T-A® Structural Steel

Cutting Data & Guaranteed Application Forms

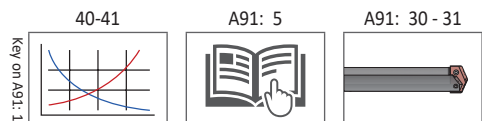

Inserts sold in multiples of 2

T-A® Structural Steel Drill Insert Holders

2 Series | Taper Shank

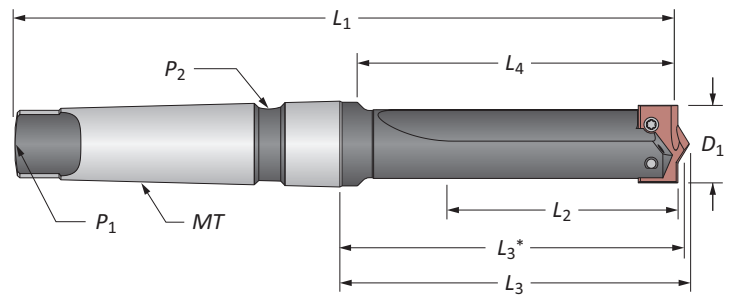

Straight Flute #4 Morse Taper

Series	Length	D_1	Body					Shank			Part No.
			L_2	L_4	L_3	L_3^*	L_1	MT	P_1	P_2	
m 2	Short	26	86	114	126.6	124.2	238	#4	TTC	TSC	22020S-004IS100
2.5	Short	30.16	86	114	126.6	124.2	238	#4	TTC	TSC	22025S-004IS112
i 2	Short	1 - 1-3/8	3-3/8	4-1/2	4-63/64	4-57/64	9-3/8	#4	TTC	TSC	22020S-004IS100
2.5	Short	1-3/16 - 1-3/8	3-3/8	4-1/2	4-63/64	4-57/64	9-3/8	#4	TTC	TSC	22025S-004IS112

*If using Structural Steel holder with Notch Point®, GEN2 T-A®, or 150° Structural Steel T-A® drill insert geometry

Connection Accessories

Series	Insert Screws	Nylon Locking Screws	Insert Driver	Preset Torque Hand Driver	Replacement Tips	Admissible Tightening Torque*
2	7495-IP15-1	7495N-IP15-1	8IP-15	8IP-15TL	8IP-15B	690 N-cm (61.0 in-lbs)
2.5	7495-IP15-1	7495N-IP15-1	8IP-15	8IP-15TL	8IP-15B	690 N-cm (61.0 in-lbs)

*Tightening torques are calculated with a friction coefficient of $\mu = 0.14$ and develop 90% of ultimate yield strength

A91: 5

A91: 28 - 29

Key on A91: 1

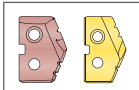

m = Metric (mm)

i = Imperial (in)

Screws sold in multiples of 10

T-A® Structural Steel Drill Insert Holders

2 Series | Taper Shank

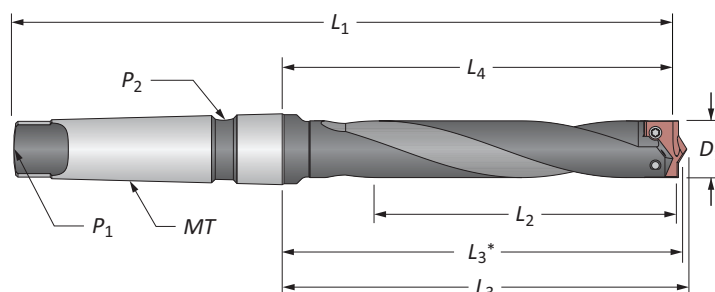

Helical Flute #3 Morse Taper

Series	Length	D ₁	Body					Shank			Part No.
			L ₂	L ₄	L ₃	L ₃ *	L ₁	MT	P ₁	P ₂	
m 2	Extended	26	165	237	247.7	240.1	336	#3	TTC	TSC	25020H-003IS100
i 2	Extended	1 - 1-3/8	6-1/2	9-11/32	9-3/4	9-29/64	13-7/32	#3	TTC	TSC	25020H-003IS100

*If using Structural Steel holder with Notch Point®, GEN2 T-A®, or 150° Structural Steel T-A® drill insert geometry

Helical Flute #4 Morse Taper

Series	Length	D ₁	Body					Shank			Part No.
			L ₂	L ₄	L ₃	L ₃ *	L ₁	MT	P ₁	P ₂	
m 2	Standard	26	137	165	177.4	175.0	289	#4	TTC	TSC	24020H-004IS100
	Extended	26	165	237	247.7	240.1	336	#4	TTC	TSC	25020H-004IS100
	Long	26	165	406	418.3	416.3	530	#4	TTC	TSC	26020H-004IS100
2.5	Standard	30.16	137	165	177.4	175.0	289	#4	TTC	TSC	24025H-004IS112
i 2	Standard	1 - 1-3/8	5-3/8	6-1/2	6-63/64	6-57/64	11-3/8	#4	TTC	TSC	24020H-004IS100
	Extended	1 - 1-3/8	6-1/2	9-7/32	9-3/4	9-43/64	15-5/32	#4	TTC	TSC	25020H-004IS100
	Long	1 - 1-3/8	6-1/2	16	16-15/32	16-25/64	20-7/8	#4	TTC	TSC	26020H-004IS100
2.5	Standard	1-3/16 - 1-3/8	5-3/8	6-1/2	6-63/64	6-57/64	11-3/8	#4	TTC	TSC	24025H-004IS112

*If using Structural Steel holder with Notch Point®, GEN2 T-A®, or 150° Structural Steel T-A® drill insert geometry

GENSYS®XT ST and Pro ST

T-A® Structural Steel

Cutting Data & Guaranteed Application Forms

m = Metric (mm)

i = Imperial (in)

Screws sold in multiples of 10

WARNING Refer to Speed and Feed charts for recommended adjustments to speeds and feeds. Refer to page A91: 35 for deep hole drilling guidelines in this section of the catalogue. Visit www.alliedmachine.com/deepholeguidelines.aspx for the most up-to-date information and procedures. Factory technical assistance is available for your specific applications through our Application Engineering Team.

T-A® Original Structural Steel Drill Inserts

3 Series | Diameter Range: 36.51mm - 39.69mm (1.4375" - 1.5625")

GEN3SYS®XT ST and Pro ST

T-A® Structural Steel



Thin Wall
For material up to 6mm thick

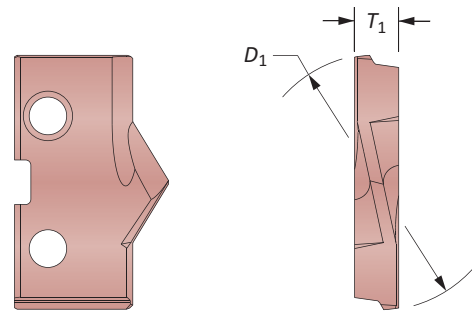

Notch Point®
For material over 6mm thick

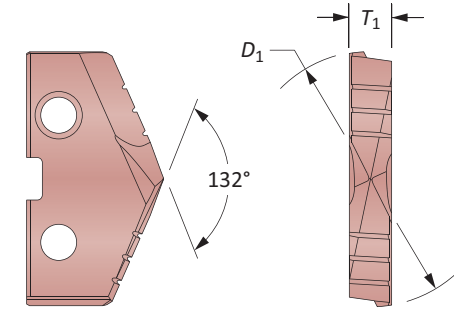

150° Structural Steel
For material over 6mm thick and for reduced exit burr

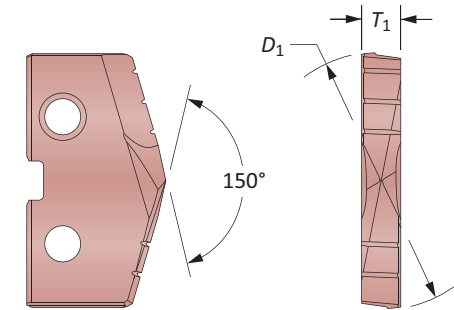

HSS Inserts – Super Cobalt

Insert				Thin Wall		Notch Point		150° Structural Steel	
Fractional Equivalent	D ₁ mm	D ₁ inch	T ₁	AM200 Part No.	TiAlN Part No.	AM200 Part No.	TiAlN Part No.	AM200 Part No.	TiAlN Part No.
1-7/16	36.51	1.4375	6.35	153H-0114-TW	153A-0114-TW	153H-0114-NP	153A-0114-NP	153H-0114-SS	153A-0114-SS
1-1/2	38.10	1.5000	6.35	153H-0116-TW	153A-0116-TW	153H-0116-NP	153A-0116-NP	153H-0116-SS	153A-0116-SS
-	39.00	1.5354	6.35	153H-39-TW	153A-39-TW	153H-39-NP	153A-39-NP	153H-39-SS	153A-39-SS
1-9/16	39.69	1.5625	6.35	153H-0118-TW	153A-0118-TW	153H-0118-NP	153A-0118-NP	153H-0118-SS	153A-0118-SS

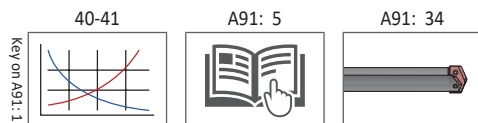

Inserts sold in multiples of 1

GEN2 T-A® Structural Steel Drill Inserts

3 Series | Diameter Range: 36.51mm - 39.69mm (1.4375" - 1.5625")

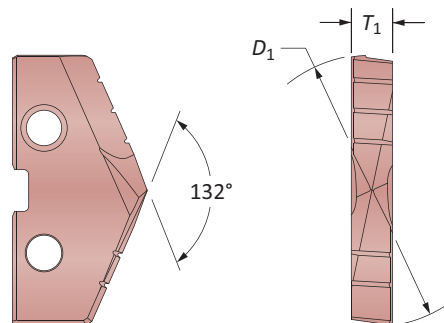
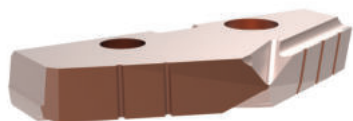

HSS Inserts – Super Cobalt

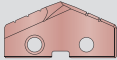
Fractional Equivalent	Insert			Part No.
	D_1 mm	D_1 inch	T_1	 Super Cobalt
1-7/16	36.51	1.4375	6.35	453H-0114-HE
1-1/2	38.10	1.5000	6.35	453H-0116-HE
-	39.00	1.5354	6.35	453H-39-HE
1-9/16	39.69	1.5625	6.35	453H-0118-HE

GEN3SYS®XT ST and Pro ST

T-A® Structural Steel

Cutting Data & Guaranteed Application Forms

Key on A91: 1

40-41

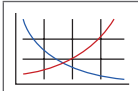

A91: 5



A91: 34



Inserts sold in multiples of 1

T-A® Structural Steel Drill Insert Holders

3 Series | Taper Shank

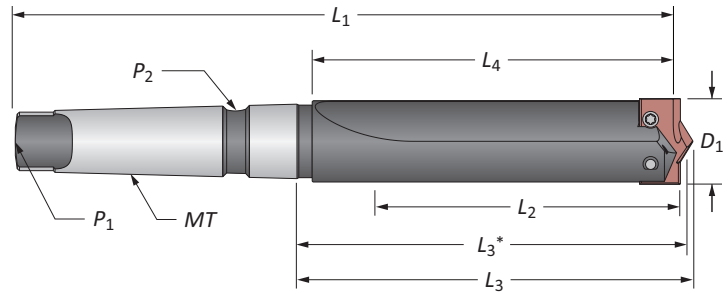

Straight Flute #4 Morse Taper

	Length	D ₁	Body				Shank			Part No.	
			L ₂	L ₄	L ₃	L ₃ *	L ₁	MT	P ₁		P ₂
m	Short	39	121	152.14	165.1	163.5	276	4	TTC	TSC	22030S-004IS126
i	Short	1-13/32 - 1-7/8	4-3/4	6	6-1/2	6-7/16	10-7/8	#4	TTC	TSC	22030S-004IS126

*If using Structural Steel holder with Notch Point®, GEN2 T-A®, or 150° Structural Steel T-A® drill insert geometry

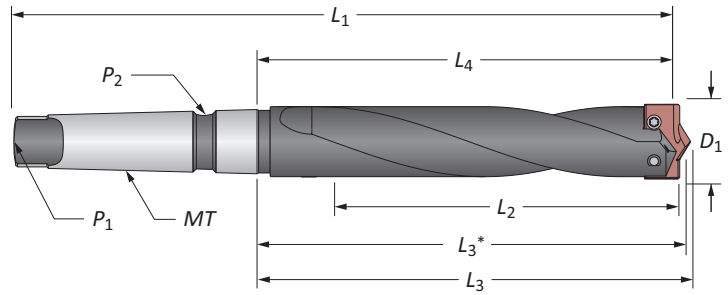

Helical Flute #4 Morse Taper

	Length	D ₁	Body				Shank			Part No.	
			L ₂	L ₄	L ₃	L ₃ *	L ₁	MT	P ₁		P ₂
m	Short	35.71	165.1	197	209.55	207.9	320.68	4	TTC	TSC	24030H-004IS126
i	Standard	1-13/32 - 1-7/8	6-1/2	7-3/4	8-1/4	8-3/16	12-5/8	#4	TTC	TSC	24030H-004IS126

*If using Structural Steel holder with Notch Point®, GEN2 T-A®, or 150° Structural Steel T-A® drill insert geometry

Connection Accessories

Insert Screws	Nylon Locking Screws	Insert Driver	Preset Torque Hand Driver	Replacement Tips	Admissible Tightening Torque*
7514-IP20-1	7514N-IP20-1	8IP-20	-	-	1370 N-cm (121.3 in-lbs)

*Tightening torques are calculated with a friction coefficient of $\mu = 0.14$ and develop 90% of ultimate yield strength

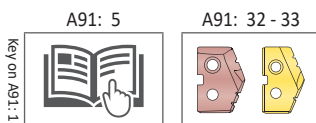

m = Metric (mm)
i = Imperial (in)
 Screws sold in multiples of 10

Deep Hole Drilling Guidelines

For Use with Drills Greater than 9xD (Extended, Long, XL, 3XL, and Special Length)

<p>1. Pilot Hole 100 % RPM 100% IPR (mm/rev)</p>	<p>Establish the pilot hole using the same diameter short drill to a depth of 2xD minimum. Utilize a pilot drill with the same or larger included point angle.</p>		<p>Coolant ON</p>
<p>2. Feed-in ⚠️ 50 RPM max 12 IPM (300 mm/min)</p>	<p>Feed the longer drill within 1/16" (1.5mm) short of the established pilot hole bottom at a maximum of 50 RPM and 12 IPM (300 mm/min) feed rate.</p>		<p>Coolant OFF</p>
<p>3. Deep Hole Transition Drilling 50 % RPM 75% IPR (mm/rev)</p>	<p>Drill additional 1xD past the bottom of the pilot hole at 50% reduction of recommended speed and 25% reduction of recommended feed. Minimum of 1 second dwell is required to meet full speed before feeding.</p>		<p>Coolant ON</p>
<p>4. Deep Hole Drilling - Blind 100% RPM 100% IPR (mm/rev)</p>	<p>Drill to full depth at recommended speed and feed for longer drill according to Allied speed and feed charts. No peck cycle recommended.</p>		<p>Coolant ON</p>
<p>5. Deep Hole Drilling - at Breakout 50% RPM 75% IPR (mm/rev)</p>	<p>For through holes only: Reduce speed by 50% and feed by 25% prior to breakout. Do not breakout more than 1/8" (3mm) past the full diameter of the drill.</p>		<p>Coolant ON</p>
<p>6. Drill Retract ⚠️ 50 RPM max</p>	<p>Reduce speed to a maximum of 50 RPM before retracting from the hole.</p>		<p>Coolant OFF</p>

1. WARNING Tool failure can cause serious injury. To prevent:

- When using holders without support bushing, use a short T-A® holder to establish an initial hole that is a minimum of 2 diameters deep.
- Do not rotate tool holders more than 50 RPM unless it is engaged with the workpiece or fixture.

Visit www.alliedmachine.com/DeepHoleGuidelines for the most up-to-date information and procedures. Factory technical assistance is available for your specific applications through our Application Engineering Team.



Recommended Cutting Data

GEN3SYS® XT Pro (XT ST)

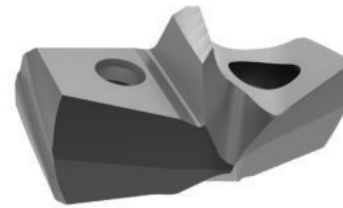

Metric (mm)

ISO	Material	Speed (M/mm) - Mist Coolant		Feed Rate (mm/rev) by Diameter			
		Hardness (BHN)	 AM420 Speed	12 series 12.00 - 12.99	13 series 13.00 - 13.99	14 series 14.00 - 14.99	15 series 15.00 - 15.99
P	Structural Steel A36, A285, A516, A572, etc.	100 - 150	107	0.20	0.22	0.25	0.25
		150 - 250	91	0.18	0.20	0.23	0.23
		250 - 350	79	0.15	0.17	0.20	0.20

Imperial (inch)

ISO	Material	Speed (SFM) - Mist Coolant		Feed Rate (IPR) by Diameter			
		Hardness (BHN)	 AM420 Speed	12 series 0.4724 - 0.5117	13 series 0.5118 - 0.5511	14 series 0.5512 - 0.5905	15 series 0.5906 - 0.6298
P	Structural Steel A36, A285, A516, A572, etc.	100 - 150	350	0.008	0.009	0.010	0.010
		150 - 250	300	0.007	0.008	0.009	0.009
		250 - 350	260	0.006	0.007	0.008	0.008

Speed and Feed Multiplier

	Depth of Cut	
	<= 1.5xD	> 1.5xD
Speed	See above chart	0.75
Feed	See above chart	0.90

NOTE: The speeds and feeds listed above are based on a rigid setup using air mist through tool coolant. Speed may be increased up to 50% if using high pressure flood or through coolant.
NOTE: If drilling dry without coolant, speed must be reduced significantly based on setup, drill depth, and material hardness. Up to 50% speed and feed reduction may be necessary in these types of applications. Contact the Application Engineering department for assistance.
NOTE: If drilling material thickness of 0.500" (12.7mm) or less, a minimum of 10% reduction in feed is required to minimize material deflection.

Feed Rate (mm/rev) by Diameter

16 series 16.00 - 16.99	17 series 17.00 - 17.99	18 series 18.00 - 19.99	20 series 20.00 - 21.99	22 series 22.00 - 23.99	24 series 24.00 - 25.99	26 series 26.00 - 28.99	29 series 29.00 - 31.99	32 series 32.00 - 35.00
0.30	0.30	0.36	0.38	0.41	0.43	0.46	0.48	0.48
0.25	0.25	0.30	0.36	0.38	0.41	0.43	0.46	0.46
0.23	0.23	0.28	0.30	0.33	0.36	0.38	0.41	0.41

Feed Rate (IPR) by Diameter



16 series 0.6299 - 0.6692	17 series 0.6693 - 0.7086	18 series 0.7087 - 0.7873	20 series 0.7874 - 0.8660	22 series 0.8661 - 0.9448	24 series 0.9449 - 1.0235	26 series 1.0236 - 1.1416	29 series 1.1417 - 1.2597	32 series 1.2598 - 1.3780
0.012	0.012	0.014	0.015	0.016	0.017	0.018	0.019	0.019
0.010	0.010	0.012	0.014	0.015	0.016	0.017	0.018	0.018
0.009	0.009	0.011	0.012	0.013	0.014	0.015	0.016	0.016

Recommended Cutting Data | Metric (mm)

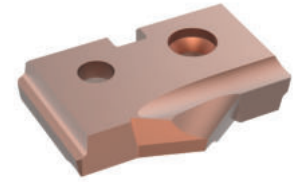
Original T-A® | GEN2 T-A®



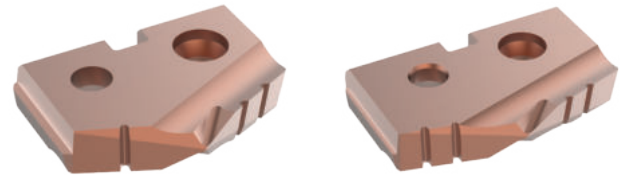

**Thin Wall Inserts
Super Cobalt**

ISO	Material	Speed (M/mm) - Mist Coolant		Feed Rate (mm/rev) by Diameter				
		Hardness (BHN)	 AM200 Speed	 TiAlN Speed	0 series 14 - 16	1 series 18 - 24	2 series 25 - 35	3 series 36 - 47
P	Structural Steel A36, A285, A516, etc.	100 - 150	39	34	0.30	0.45	0.48	0.50
		150 - 250	35	31	0.28	0.40	0.43	0.48
		250 - 350	32	28	0.25	0.36	0.40	0.45



**Notch Point® and 150° Structural Steel Inserts
Super Cobalt**

ISO	Material	Speed (M/mm) - Mist Coolant		Feed Rate (mm/rev) by Diameter				
		Hardness (BHN)	 AM200 Speed	 TiAlN Speed	0 series 14 - 16	1 series 18 - 24	2 series 25 - 35	3 series 36 - 47
P	Structural Steel A36, A285, A516, etc.	100 - 150	39	34	0.25	0.30	0.36	0.45
		150 - 250	35	31	0.23	0.28	0.30	0.40
		250 - 350	35	28	0.20	0.25	0.28	0.36

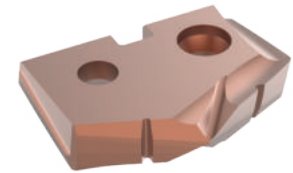

**GEN2 T-A Inserts
Super Cobalt**

ISO	Material	Speed (M/mm) - Mist Coolant		Feed Rate (mm/rev) by Diameter			
		Hardness (BHN)	 AM200 Speed	0 series 14 - 16	1 series 18 - 24	2 series 25 - 35	3 series 36 - 47
P	Structural Steel A36, A285, A516, etc.	100 - 150	39	0.25	0.30	0.36	0.46
		150 - 250	35	0.23	0.28	0.30	0.40
		250 - 350	35	0.20	0.25	0.28	0.36

**GEN2 T-A Inserts
Carbide C1 (K35)**

ISO	Material	Speed (M/mm) - Mist Coolant		Feed Rate (mm/rev) by Diameter			
		Hardness (BHN)	 AM200 Speed	0 series 14 - 16	1 series 18 - 24	2 series 25 - 35	3 series 36 - 47
P	Structural Steel A36, A285, A516, etc.	100 - 150	50	0.20	0.28	0.38	0.43
		150 - 250	47	0.15	0.25	0.33	0.38
		250 - 350	43	0.13	0.23	0.30	0.33



NOTE: The speeds and feeds listed above are based on a rigid setup using air mist through tool coolant. Speed may be increased up to 50% if using high pressure flood or through coolant.
NOTE: If drilling dry without coolant, speed must be reduced significantly based on setup, drill depth, and material hardness. Up to 50% speed and feed reduction may be necessary in these types of applications. Contact the Application Engineering department for assistance.

Recommended Cutting Data | Imperial (inch)

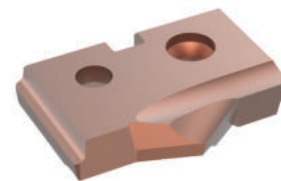
Original T-A® | GEN2 T-A®



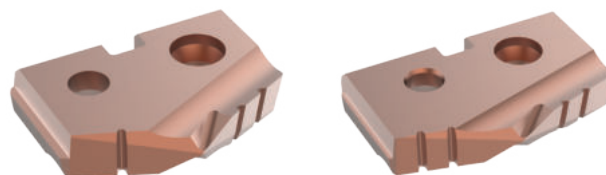

Thin Wall Inserts Super Cobalt

ISO	Material	Speed (SFM) - Mist Coolant		Feed Rate (IPR) by Diameter				
		Hardness (BHN)	 AM200 Speed	 TiAlN Speed	0 series 9/16 - 11/16	1 series 13/16 - 15/16	2 series 1 - 1-3/8	3 series 1-13/32 - 1-7/8
P	Structural Steel A36, A285, A516, etc.	100 - 150	125	110	0.012	0.018	0.019	0.020
		150 - 250	115	100	0.011	0.016	0.017	0.019
		250 - 350	105	90	0.010	0.014	0.016	0.018



Notch Point® and 150° Structural Steel Inserts Super Cobalt

ISO	Material	Speed (SFM) - Mist Coolant		Feed Rate (IPR) by Diameter				
		Hardness (BHN)	 AM200 Speed	 TiAlN Speed	0 series 9/16 - 11/16	1 series 13/16 - 15/16	2 series 1 - 1-3/8	3 series 1-13/32 - 1-7/8
P	Structural Steel A36, A285, A516, etc.	100 - 150	125	110	0.010	0.012	0.014	0.018
		150 - 250	115	100	0.009	0.011	0.012	0.016
		250 - 350	105	90	0.008	0.010	0.011	0.014

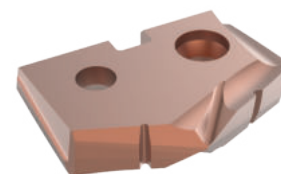

GEN2 T-A Inserts Super Cobalt

ISO	Material	Speed (SFM) - Mist Coolant		Feed Rate (IPR) by Diameter			
		Hardness (BHN)	 AM200 Speed	0 series 9/16 - 11/16	1 series 13/16 - 15/16	2 series 1 - 1-3/8	3 series 1-13/32 - 1-7/8
P	Structural Steel A36, A285, A516, etc.	100 - 150	125	0.010	0.012	0.014	0.018
		150 - 250	115	0.009	0.011	0.012	0.016
		250 - 350	105	0.008	0.010	0.011	0.014

GEN2 T-A Inserts Carbide C1 (K35)

ISO	Material	Speed (SFM) - Mist Coolant		Feed Rate (IPR) by Diameter			
		Hardness (BHN)	 AM200 Speed	0 series 9/16 - 11/16	1 series 13/16 - 15/16	2 series 1 - 1-3/8	3 series 1-13/32 - 1-7/8
P	Structural Steel A36, A285, A516, etc.	100 - 150	165	0.008	0.011	0.015	0.017
		150 - 250	155	0.006	0.010	0.013	0.015
		250 - 350	140	0.005	0.009	0.012	0.013

NOTE: The speeds and feeds listed above are based on a rigid setup using air mist through tool coolant. Speed may be increased up to 50% if using high pressure flood or through coolant.
NOTE: If drilling dry without coolant, speed must be reduced significantly based on setup, drill depth, and material hardness. Up to 50% speed and feed reduction may be necessary in these types of applications. Contact the Application Engineering department for assistance.

GEN3SYS®XT ST and Pro ST

T-A® Structural Steel

Cutting Data & Guaranteed Application Forms



Guaranteed Application Request Structural Steel

Guidelines on use

Guidelines for use of the Guaranteed Request Form

The request for a Guaranteed Application is a method of proving AMEC tooling on demonstration.

The Guaranteed Application form must be completed as fully as possible and sent to the Allied Machine Technical Department.

Example - Required Informations

Contact Details:

Purchase Order Number
 Date
 Customer Name
 Customer Telephone and Fax Number
 Proposed Date of the Demonstration
 Customer Contact Name

Application Information:

Material: Type, Specification, Hardness, Condition, Thickness
 Hole: Diameter, Diameter Range

Machine and Set-up Information:

Machine: Type, Model, Feedline, Control, Speed, Preferred Shank Type
 Spindle: Orientation, Type
 Coolant: Type, Feed

Current Drill Information:

Details of current, or previous tooling used on application, and its performance history

What defines a successful test:

The objective of the demonstration i.e. Decreased Cycle Time, Better Chip Control, Safer Process, Longer Tool Life and Reduced Cost per Hole

Providing the Allied Machine Technical Department have enough information to judge the application, and its objectives are feasible, the test will be approved.

Structural Steel Guaranteed Application Form

Distributor PO #

The Following must be filled out completely before your test will be considered

CONTACT DETAILS

Trial P.O No* Date* Proposed Test Date*
 Distributor* Distributor Contact*
 Customer Name* Industry..... Contact Name*
 Contact Telephone* Contact E-mail*

APPLICATION INFORMATION

ATTENTION: The following Information is required to enable the best combination of tooling to be recommended. Please complete all that apply.
 Material Type* Specification* Material Hardness Kg BRN RC N/mm²
 Material Condition Angle H-Section Tubular Stock
 Stacked Plate Plate U-Section
 Hole Diameter mm Inch Hole Diameter Range used..... mm Inch
 Material Thickness this test Material Thickness Range used *

MACHINE AND SET-UP INFORMATION

Machine Tool Type Ficep Steeltec Pedestal Drill
 Peddinghaus Voortman Vernet Behringer
 Kaltenbach Radial Arm Other
 Model*
 Feedline* Hydraulic Ball Screw
 Machine Tool Control* CNC NC Manual Other
 Spindle Orientation* Vertical Horizontal Other
 Spindle Type* ISO Quick Change Morse Taper No Gauge Length mm Inch
 Available Speed* Variable Fixed RPM m/Min
 Preferred Shank Type* Flanged Morse Taper N°..... Diameter mm Inch
 Coolant Type* Cutting Oil Water Soluble Oil Air Mist Air Dry
 Coolant Feed* Constant Pulsed Through Coolant External

CURRENT DRILL INFORMATION

Drill Manufacturer Point Angle
 Drill Type Twist Brazed Indexable Insert
 Removable Tip Other
 Tool Grade HSS Carbide Other
 Tool Coating Uncoated TiN TiCN TiAlN Other
 Current Speed RPM m/Min Current Feed Rate mm/rev mm/min
 Average Number of Holes Drilled New After Regrind?
 Reason(s) for Tool change Wear Fracture Chipping
 Losing Hole Tolerance Losing Chip Control Other
 Other Chatter New Application
 What Criteria define a successful test* Decreased Cycle Time Better Chip Control Safer Process
 Longer Tool Life Reduced Cost per Hole Other

Potential this application: Current Annual Usage €/£: Tools per Annum?

*Required Fields where applicable

FOR OFFICE USE ONLY

Application Engineer: Number: Status:



ALLIED MACHINE & ENGINEERING

Warranty Information



Allied Machine & Engineering warrants to original equipment manufacturers, distributors, industrial and commercial users of its products that each new product manufactured or supplied by Allied Machine shall be free from defects in material and workmanship.

Allied Machine's obligation under this warranty is limited to furnishing without additional charge a replacement or, at its option repairing or issuing credit for any product which shall within one year from the date of sale be returned freight prepaid to the plant designated by an Allied Machine representative and which upon inspection is determined by Allied Machine to be defective in materials or workmanship.

Complete information as to operating conditions, machine, set-up and application of cutting fluid should accompany any product returned for inspection. The provisions of this warranty shall not apply to any Allied Machine products which have been subjected to misuse, improper operating conditions, machine set-up or application of cutting fluid or which have been repaired or altered if such repair or alteration in the judgment of Allied Machine would adversely affect performance of the product.

THIS WARRANTY IS IN LIEU OF ALL OTHER WARRANTIES, EXPRESS OR IMPLIED, INCLUDING ANY IMPLIED WARRANTY OF MERCHANTABILITY OR FITNESS FOR A PARTICULAR PURPOSE. Allied Machine shall have no liability or responsibility on any claim of any kind, whether in contract, tort or otherwise, for any loss or damage arising out of, connected with, or resulting from the manufacture, sale, delivery or use of any product sold hereunder, in excess of the cost of replacement or repair as provided herein.

ALL PRICES, DELIVERIES, DESIGNS and MATERIALS ARE SUBJECT TO CHANGE WITHOUT NOTICE.



Allied Machine & Engineering
Registered to ISO 9001
10001329

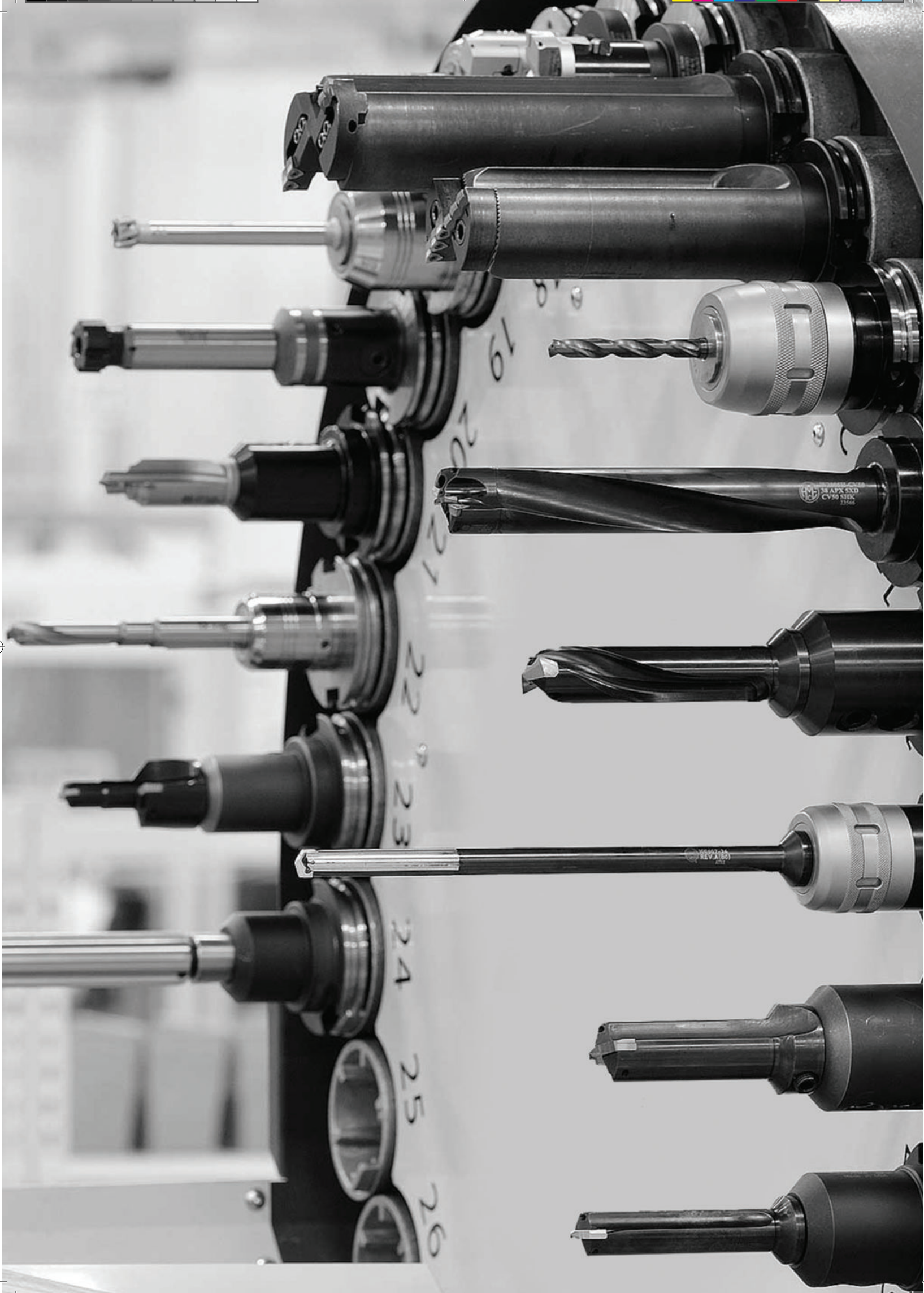

Europe

Allied Machine & Engineering Co. (Europe) Ltd.

93 Vantage Point
Pensnett Estate
Kingswinford
West Midlands
DY6 7FR England

Phone:

+44 (0)1384 400900

Email:

enquiries.eu@alliedmachine.com

Web:

www.alliedmachine.com

Wohlhaupter GmbH

Maybachstraße 4
72636 Frickenhausen
Germany

Phone:

+49 (0)7022 408 0

Email:

info@wohlhaupter.de

Web:

www.wohlhaupter.com

United States

Allied Machine & Engineering

120 Deeds Drive
Dover OH 44622
United States

Phone:

+1 330 343 4283

Fax:

+1 330 602 3400

Toll Free USA and Canada:

800 321 5537

Toll Free USA and Canada:

800 223 5140

Allied Machine & Engineering

485 W Third Street
Dover OH 44622
United States

Phone:

+1 330 343 4283

Fax:

+1 330 364 7666
(Engineering Dept.)

Toll Free USA and Canada:

800 321 5537

Asia

Wohlhaupter India Pvt. Ltd.

B-23, 2nd Floor
B Block Community Centre
Janakpuri, New Delhi - 110058
India

Phone:

+91 11 41827044

Your local Allied Machine representative:



**ALLIED MACHINE
& ENGINEERING**

WOHLHAUPTER®

Holemaking Solutions for Today's Manufacturing